

" There are as many atoms in a single molecule of your DNA as there are stars in the typical galaxy. We are, each of us, a little universe."

- **Neil Degrass Tyson**

**NATURAL  
SCIENCES  
&  
TECHNOLOGY**

LESSON PLAN  
GRADE 6 TERM 4



# A MESSAGE FROM THE NECT

NATIONAL EDUCATION COLLABORATION TRUST (NECT)

**Dear Teachers,**

This learning programme and training is provided by the National Education Collaboration Trust (NECT) on behalf of the Department of Basic Education (DBE)! We hope that this programme provides you with additional skills, methodologies and content knowledge that you can use to teach your learners more effectively.

## **What is NECT?**

In 2012 our government launched the National Development Plan (NDP) as a way to eliminate poverty and reduce inequality by the year 2030. Improving education is an important goal in the NDP which states that 90% of learners will pass Maths, Science and languages with at least 50% by 2030. This is a very ambitious goal for the DBE to achieve on its own, so the NECT was established in 2015 to assist in improving education and to help the DBE reach the NDP goals.

The NECT has successfully brought together groups of relevant people so that we can work collaboratively to improve education. These groups include the teacher unions, businesses, religious groups, trusts, foundations and NGOs.

## **What are the Learning programmes?**

One of the programmes that the NECT implements on behalf of the DBE is the 'District Development Programme'. This programme works directly with district officials, principals, teachers, parents and learners; you are all part of this programme!

The programme began in 2015 with a small group of schools called the Fresh Start Schools (FSS). Curriculum learning programmes were developed for Maths, Science and Language teachers in FSS who received training and support on their implementation. The FSS teachers remain part of the programme, and we encourage them to mentor and share their experience with other teachers.

The FSS helped the DBE trial the NECT learning programmes so that they could be improved and used by many more teachers. NECT has already begun this embedding process.

Everyone using the learning programmes comes from one of these groups; but you are now brought together in the spirit of collaboration that defines the manner in which the NECT works. Teachers with more experience using the learning programmes will deepen their knowledge and understanding, while some teachers will be experiencing the learning programmes for the first time.

Let's work together constructively in the spirit of collaboration so that we can help South Africa eliminate poverty and improve education!

[www.nect.org.za](http://www.nect.org.za)

# CONTENTS

<b>PROGRAMME ORIENTATION</b>	4
<b>CAPS AND THE LESSON PLANS</b>	8-13
<b>TOPIC OVERVIEW PLANET EARTH 1A -3A</b>	14-15
Week 1 Lesson 1A	16
Week 1 Lesson 1B	21
Week 1 Lesson 1C	26
Week 2 Lesson 2A	32
Week 2 Lesson 2B	39
Week 2 Lesson 2C	45
Week 3 Lesson 3A	51
<b>TOPIC OVERVIEW EARTH &amp; BEYOND 3B - 4A</b>	56-57
Week 3 Lesson 3B	58
Week 3 Lesson 3C	62
Week 4 Lesson 4A	68
<b>TOPIC OVERVIEW THE MOVEMENT OF THE MOON 4B - 5A</b>	75-76
Week 4 Lesson 4B	77
Week 4 Lesson 4C	83
Week 5 Lesson 5A	88
<b>TOPIC OVERVIEW SYSTEMS FOR LOOKING INTO SPACE 5B - 6A</b>	94-95
Week 5 Lesson 5B	96
Week 5 Lesson 5C	101
Week 6 Lesson 6A	105
<b>TOPIC OVERVIEW PLANET EARTH AND BEYOND 6B - 8B</b>	110-112
Week 6 Lesson 6B	113
Week 6 Lesson 6C	118
Week 7 Lesson 7A	123
Week 7 Lesson 7B	127
Week 7 Lesson 7C	132
Week 8 Lesson 8A	136
Week 8 Lesson 8B	139
Week 8 Lesson 8C	143
<b>GRADE 6 ASSESSMENT</b>	148-149
Term 4 Assessment: Practical Task	151
Term 4 Assessment: Practical Task Memo	153
Term 4 Assessment: Exam	154
Term 4 Assessment: Exam Memo	162

# PROGRAMME ORIENTATION

Welcome to the NECT Natural Sciences & Technology learning programme! This CAPS compliant programme consists of:

- A full set of lesson plans for the term (3 lessons per week)
- A resource pack with images to support the lesson plans
- A full colour poster for one topic
- An outline of the assessment requirements for the term
- A tracker to help you monitor your progress

## Lesson Plan Structure

1. The Term 4 lesson plan is structured to run for 8 weeks.
2. Each week, there are three lessons, of the following notional time:

1 x 1 hour 30 minutes

2 x 1 hour

This time allocation of 3.5 hours per week is CAPS aligned.

## Lesson Plan Contents

1. The lesson plan starts with a **CONTENTS PAGE** that lists all the topics for the term, together with a breakdown of the lessons for that topic. You will notice that lessons are named by the week and lesson number, for example, Week 8 Lesson 8C.
2. Every topic begins with a 2 - 4 page **TOPIC OVERVIEW**. The topic overview pages are grey, making them easy to identify. The topic overview can be used to introduce the topic to learners. The topic overview includes:
  - a. A **general introduction** to the topic that states how long the topic runs for, the value of the topic in the final exam and the number of lessons in the topic.
  - b. A table showing the **position of the topic** in the term.
  - c. A **sequential table** that shows the prior knowledge required for this topic, the current knowledge and skills that will be covered, and how this topic will be built on in future years. Use this table to give learners an informal quiz to test their prior knowledge. If learners are clearly lacking in the knowledge and skills required, you may need to take a lesson to cover some of the essential content and skills. It is also useful to see what you are preparing learners for next, by closely examining the 'looking forward' column.
  - d. A glossary of **scientific and technological vocabulary**, together with an explanation of each word or phrase. It is a good idea to display these words and their definitions somewhere in the classroom, for the duration of the topic. It is also a good idea to allow learners some time to copy down these words into their personal dictionaries or science exercise books. You must explicitly teach the words and their meanings as and when you encounter these words in the topic. A good way to teach learners new vocabulary is to use 'PATS':

## PROGRAMME ORIENTATION

- POINT – if the word is a noun, point at the object or at a picture of the object as you say the word.
  - ACT – if the word is a verb, try to act out or gesture to explain the meaning of the word, as you say it.
  - TELL – if the word has a more abstract meaning, then tell the learners the meaning of the word. You may need to code switch at this point, but also try to provide a simple English explanation.
  - SAY – say the word in a sentence to reinforce the meaning.
- e. Understanding the uses / value of natural sciences & technology.** It is very important to give learners a sense of how science applies to their daily lives, and of the value that science adds to their lives. Hold a brief discussion on this point when introducing the topic, and invite learners to elaborate on the uses and value that this topic will have to their lives.
- f. Personal reflection.** At the end of every topic, come back to the topic overview, and complete this table. In particular, it is important to note your challenges and ideas for future improvement, so that you can improve your teaching the next year.
3. After the topic overview, you will find the **INDIVIDUAL LESSONS**. Every lesson is structured in exactly the same way. This helps you and the learners to anticipate what is coming next, so that you can focus on the content and skills. Together with the title, each lesson plan includes the following:
- a. Policy and Outcomes.** This provides you with the CAPS reference, and an overview of the skills that will be covered in the lesson. You can immediately see the SCIENCE PROCESS AND DESIGN SKILLS that will be covered, and whether they are lower or higher order skills.
  - b. Possible Resources.** Here, you will see the resources that you should ideally have for the lesson. If you need to use the poster or pages from the resource pack, this will be listed here. There is also a space for improvised resources, and you are invited to add your own ideas here.
  - c. Classroom Management.** Every lesson starts in the same way. Before the lesson, you must write a question that relates to the previous lesson on the chalkboard. Train your learners to come in to the classroom, to take out their exercise books, and to immediately try to answer this question. This links your lesson to the previous lesson, and it effectively settles your learners.  
  
Once learners have had a few minutes to answer, read the question and discuss the answer. You may want to offer a small reward to the learner who answers first, or best. Get your learners used to this routine.  
  
Next, make sure that you are ready to begin your lesson, have all your resources ready, have notes written up on the chalkboard, and be fully prepared to start. Remember, learners will get restless and misbehave if you do not keep them busy and focussed.
- Accessing Information.** This section contains the key content that you need to share with learners. Generally, it involves sharing some new information that is written on the chalkboard, explaining this information, and allowing learners some time to copy the information into their exercise books. Train learners to do this quickly and efficiently. Learners must anticipate this part of the lesson, and must have their books, pens, pencils and rulers ready.

## PROGRAMME ORIENTATION

Explain to learners that this is an important resource for them, because these are the notes they will revise when preparing for tests and exams.

**Checkpoint 1.** Straight after 'Accessing Information', you will find two checkpoint questions. These questions help you to check that learners understand the new content thus far.

- e. Conceptual Development.** At this point, learners will have to complete an activity to think about and apply their new knowledge, or to learn a new skill. This is the most challenging part of the lesson. Make sure that you fully understand what is required, and give learners clear instructions.

**Checkpoint 2.** Straight after 'Conceptual Development, you will find two checkpoint questions. These questions help you to check that learners understand the new concepts and skills that they have engaged with.

- f. Reference Points for Further Development.** This is a useful table that lists the relevant sections in each approved textbook. You may choose to do a textbook activity with learners in addition to the lesson plan activity, or even in place of the lesson plan activity. You may also want to give learners an additional activity to do for homework.

- g. Additional Activities / Reading.** This is the final section of the lesson plan. This section provides you with web links related to the topic. Try to get into the habit of visiting these links as part of your lesson preparation. As a teacher, it is always a good idea to be more informed than your learners.

4. At the end of the week, make sure that you turn to the **TRACKER**, and make note of your progress. This helps you to monitor your pacing and curriculum coverage. If you fall behind, make a plan to catch up.
5. **POSTER AND RESOURCE PACK.** You will have seen that the *Possible Resource* section in the lesson plan will let you know which poster or reference pages you will need to use in a lesson.

Please note that you will only be given these resources once. It is important for you to manage and store these resources properly. Do this by:

- Writing your name on all resources
- Sticking Resource onto cardboard or paper
- Laminating all resources, or covering them in contact paper
- Filing the resource papers in plastic sleeves once you have completed a topic

Have a dedicated wall or notice board in your classroom for Natural Science and Technology.

- Use this space to display the resources for the topic
- Display the vocabulary words and meaning here, as well as the resources
- Try to make this an attractive and interesting space
- Display learners' work on this wall – this gives learners a sense of ownership and pride.

## PROGRAMME ORIENTATION

- 6. ASSESSMENT.** At the end of the lesson plans, you will find the CAPS assessment requirements for the term. You should refer to your prescribed textbooks and departmental resources for examples of the relevant assessments.

### Lesson Plan Routine

Train your learners to know and anticipate the routine of Natural Science and Technology lessons. You will soon see that a good knowledge of this routine will improve time-on-task and general classroom discipline and that you will manage to work at a quicker pace.

*Remember, every Natural Science and Technology lesson follows this routine:*

- 1. Classroom Management:** settle learners by having two questions written on the chalkboard. Learners take out their exercise books and pens, and immediately answer the questions. Discuss the answers to the questions, and reward the successful learner.
- 2. Accessing Information:** have key information written on the chalkboard. Explain this to learners. Allow learners to copy this information into their books.
- 3. Checkpoint 1:** ask learners two questions to check their understanding.
- 4. Conceptual Development:** complete an activity to apply new knowledge or skills.
- 5. Checkpoint 2:** ask learners two questions to check their understanding.
- 6. Reference Points for Further Development:** links to textbook activities – you may choose to use these activities as additional classwork activities, or as homework activities.
- 7. Tracker:** fill in your tracker at the end of the week to track your progress.

# PROGRAMME ORIENTATION

## A vehicle to implement CAPS

Teaching Natural Sciences & Technology can be exciting and rewarding. These lesson plans have been designed to guide you to implement the CAPS policy in a way that makes the teaching and learning experience rewarding for both the teacher and the learners.

To support the policy's fundamentals of teaching Natural Sciences & Technology, these lesson plans use the CAPS content as a basis and:

- provide a variety of teaching techniques and approaches
- promote enjoyment and curiosity
- highlight the relationship between Natural Science and Technology and other subjects
- where appropriate, draw on and emphasise cultural contexts and indigenous knowledge systems
- show the relationship between science, learners, their societies and their environments
- aim to prepare learners for economic activity and self-expression

## Content and Time Allocation

These lessons plans have been developed to comply with CAPS in respect of both content and time allocation. In developing these lesson plans, we took into consideration the realities of teachers and to this end, we made some simple adjustments, without deviating from policy, to make the teaching of these lesson plans more achievable. The kinds of adjustments made include using some of the practical tasks in the lesson plans for assessment purposes; and building in time for revision and exams during terms 2 and 4.

CAPS assigns one knowledge strand to form the basis of content in each term. These strands are as follows:

- Term 1: ***Life and Living***
- Term 2: ***Matter and Materials***
- Term 3: ***Energy and Change***
- Term 4: ***Planet Earth and Beyond***

In most terms, there are Technology knowledge strands that complement the Natural Sciences strands. There are three Technology strands, they are:

- ***Structures***
- ***Systems and Control***
- ***Processing***



# PROGRAMME ORIENTATION

The distribution of these strands across the year is summarised in the table below:

Grade 6					
Term 1	Term 2	Term 3	Term 4	Strands NS & Tech	
Strands NS & Tech	Strands NS & Tech	Strands NS & Tech	Strands NS & Tech	Planet Earth and Beyond	Systems and Control
<b>Life and Living</b> Photosynthesis Nutrients in Food Nutrition Eco Systems and food webs	<b>Matter and Materials</b> Solids, liquids and gases Mixtures Solutions as special mixtures Mixtures and water resources	<b>Processing</b> Processes to purify water	<b>Energy and Change</b> Electric circuits Electrical conductors and insulators Mains electricity	<b>Planet Earth and Beyond</b> The solar system Movements of the earth and planets The movement of the Moon	<b>Systems and Control</b> Systems looking into space Systems to solve problems Systems to explore the Moon and Mars

These lesson plans have been designed against the stipulated CAPS requirements with topics being allocated for the time prescribed by CAPS. (Remember that some slight changes have been incorporated to accommodate time for revision, tests and examinations).

## PROGRAMME ORIENTATION

These lesson plans have been designed against the stipulated CAPS requirements with topics being allocated for the time prescribed by CAPS. (Remember that some slight changes have been incorporated to accommodate time for revision, tests and examinations).

The time allocation by topic is summarised in the table below.

Remember that one week equates to 3,5 hours or three lessons: two lessons of 1 hour each; and one lesson of 1½ hours.

	GRADE 4		GRADE 5		GRADE 6	
TERM	Topic	Time in weeks	Topic	Time in weeks	Topic	Time in weeks
<b>Term 1:</b> Life and Living	• Living and non-living things	2	• Plants and animals on Earth	2½	• Photosynthesis	2½
	• Structures of plants and animals	2½	• Animal Skeletons	1½	• Nutrients in Food	1½
	• What plants need to grow	1	• Food Chains	2½	• Nutrition	1½
	• Habitats of animals	1	• Life cycles	1½	• Food Processing	2½
	• Structures for animal shelters	2½	• Skeletons and Structures	2	• Eco Systems and food webs	2
		(10 wks)		(10 wks)		(10 wks)
<b>Term 2:</b> Matter and Materials	• Materials around us	3½	• Metals and non-metals	2	• Solids, liquids and gases	½
	• Solid materials	2	• Uses of metals	2½	• Mixtures	1
	• Strengthening materials	2	• Processing materials	3½	• Solutions as special mixtures	2½
	• Strong frame structures	2½	• Processed materials	2	• Dissolving	1
			(10 wks)		• Mixtures and water resources	2½
		(10 wks)		• Processes to purify water	2½	(10 wks)

## PROGRAMME ORIENTATION

<b>Term 3:</b>  Energy and Change	• Energy and Energy transfer	2½	• Stored energy in fuels	3	• Electric circuits	2½
	• Energy around us	2½	• Energy and electricity	3	• Electrical conductors and insulators	2
	• Movement energy in a system	2½	• Energy and movement	1	• Systems to solve problems	2½
	• Energy and sound	2½	• Systems for moving things	3	• Mains electricity	3
		(10 wks)		(10 wks)		(10 wks)
<b>Term 4:</b>  Planet Earth and Beyond	• Planet Earth	2	• Planet Earth	1	• The solar system	2½
	• The Sun	1	• Surface of the Earth	2½	• Movements of the earth and planets	1
	• The Earth & the Sun	1	• Sedimentary Rocks	2	• The movement of the Moon	1
	• The Moon	2	• Fossils	2½	• Systems looking into space	1
	• Rocket Systems	2			• Systems to explore the Moon and Mars	2½
		(8 wks)		(8 wks)		(8 wks)
<b>TOTALS</b>	38 weeks		38 weeks		38 weeks	

# PROGRAMME ORIENTATION

## REFLECTING ON THE LESSONS THAT YOU TEACH

It is important to reflect on your teaching. Through reflection, we become aware of what is working and what is not, what we need to change and what we do not. Reflecting on your use of these lesson plans will also help you use them more effectively and efficiently.

These lesson plans have been designed to help you deliver the content and skills associated with CAPS. For this reason, it is very important that you stick to the format and flow of the lessons. CAPS requires a lot of content and skills to be covered – this makes preparation and following the lesson structure very important.

Use the tool below to help you reflect on the lessons that you teach. You do not need to use this for every lesson that you teach – but it is a good idea to use it a few times when you start to use these lessons. This way, you can make sure that you are on track and that you and your learners are getting the most out of the lessons.

<b>LESSON REFLECTION TOOL</b>		
<b>Preparation</b>		
1.	What preparation was done?	
2.	Was preparation sufficient?	
3.	What could have been done better?	
4.	Were all of the necessary resources available?	
<b>Classroom Management</b>		
		<b>Yes</b>
		<b>No</b>
5.	Was there a question written in the board?	
6.	Was there an answer written on the board?	
7.	Was the answer discussed with the learners in a meaningful way?	
8.	Overall reflection on this part of the lesson: What was done well? What could have been done better?	

## PROGRAMME ORIENTATION

### Accessing Information

		Yes	No
9.	Was the text and/ or diagrams written on the chalkboard before the lesson started?		
10.	Was the work on the board neat and easy for the learners to read?		
11.	Was the explanation on the content easy to follow?		
12.	Was the information on the board used effectively to help with the explanations?		
13.	Was any new vocabulary taught effectively? (in context and using strategies like PATS)		
14.	Were the learners actively engaged? (asked questions, asked for their opinions and to give ideas or suggestions)		
15.	Were the checklist questions used effectively?		
16.	Overall reflection on this part of the lesson: What was done well? What could have been done better?		

### Conceptual Development

		Yes	No
17.	Was the information taught in the 'Accessing Information' part of the lesson used to foreground the activity?		
18.	Were clear instructions given for the conceptual development activity?		
19.	Were the outcomes/answers to the activities explained to the learners?		
20.	Could the learners ask questions and were explanations given?		
21.	Was a model answer supplied to the learners? (written or drawn on the board)		
21.	Were the checklist questions used effectively?		
22.	At the end of the lesson, were the learners asked if they had questions or if they needed any explanations?		
23.	Overall reflection on this part of the lesson: What was done well? What could have been done better?		

# TOPIC OVERVIEW:

## Earth and Beyond

### Term 4, Weeks 1A – 3A

#### A. TOPIC OVERVIEW

##### Term 4, Weeks 1a – 3a

- This topic runs for 2 ½ weeks.
- This topic counts for 28% in the end of year final exam.
- It is presented over 7 lessons.
- This topic's position in the term is as follows:

LESSON	WEEK 1			WEEK 2			WEEK 3			WEEK 4			WEEK 5		
	A	B	C	A	B	C	A	B	C	A	B	C	A	B	C

LESSON	WEEK 6			WEEK 7			WEEK 8			WEEK 9			WEEK 10		
	A	B	C	A	B	C	A	B	C	A	B	C	A	B	C

#### B. SEQUENTIAL TABLE

GRADE 5	GRADE 6	GRADE 6 & 8
<b>LOOKING BACK</b>	<b>CURRENT</b>	<b>LOOKING FORWARD</b>
<ul style="list-style-type: none"> <li>• Planet Earth: features and its place in Space; orbiting the Sun, spinning on its axis; the surface of the Earth</li> <li>• Sedimentary rocks: formation and uses</li> <li>• Fossils: in rock; body and trace fossils; South African fossils</li> <li>• The Sun: a star giving out heat and light, providing heat and light for Earth</li> <li>• The Moon: features; phases; cultural stories</li> <li>• Rockets: purpose; how they are propelled; design, make and evaluate</li> </ul>	<ul style="list-style-type: none"> <li>• The Solar System: Sun, planets, asteroids, moons</li> <li>• Movements of the Earth, the Moon and planets: rotation and revolution</li> <li>• Systems for looking into space: telescopes; South Africa's large telescopes</li> <li>• Systems to explore the Moon and Mars: vehicles; design, make and evaluate</li> </ul>	<ul style="list-style-type: none"> <li>• The Solar System: Sun, planets; asteroids; dwarf planets; Earth's relative position</li> <li>• The Milky Way, galaxy and beyond</li> <li>• Relationship of the Sun to the Earth: solar energy and the seasons; solar energy and life on Earth; stored solar energy</li> <li>• Relationship of the Moon to the Earth: relative positions; gravity; tides</li> <li>• Astronomy: historical development; early indigenous knowledge; modern developments</li> </ul>

- Viewing the night sky: early viewing; different types of telescopes

### C. SCIENTIFIC AND TECHNOLOGICAL VOCABULARY

Ensure that you teach the following vocabulary at the appropriate place in the topic:

	TERM	EXPLANATION
1.	star	A very large ball of burning gas in space that is usually seen from Earth as a twinkling light in the sky at night; it gives off its own heat and light.
2.	planet	An object in Space that is smaller than a star; it reflects light from the star around which it orbits.
2.	Solar System	Consists of the Sun and all the objects, that orbit around it. For example: planets, asteroids and comets.
4.	orbit	The path a planet travels around the Sun.
5.	gas	A substance that is not a solid or a liquid but is in a form like air. Examples of gases are oxygen and hydrogen.
6.	atmosphere	The layer of gas that surrounds (blankets) a planet.
7.	asteroid	A piece of rock or metal that orbits the Sun.
8.	space	The area outside Earth's atmosphere, where the planets and the stars are.
9.	axis	An imaginary line through the Earth (or other planets). The Earth spins around this line.

### D. UNDERSTANDING THE USES / VALUE OF SCIENCE

If you are interested in the Solar System, you might want to become an astronomer or an astronaut. An astronomer is a scientist who studies objects in Space. An astronaut travels in Space. There are large telescopes in South Africa. The building of these telescopes have needed engineers, scientists, information technologists and astronomers.

### E. PERSONAL REFLECTION

Reflect on your teaching at the end of each topic:

Date completed:	
Lesson successes:	
Lesson challenges:	
Notes for future improvement:	

**1 A**

**Term 4, Week 1, Lesson A**

**Lesson Title: The Sun, Planets and Asteroids**

**Time for lesson: 1 hour**

**A POLICY AND OUTCOMES**

<b>Sub-Topic</b>	The Sun, Planets and the Eight Planets
<b>CAPS Page Number</b>	61

**Lesson Objectives**

By the end of the lesson, learners will be able to:

- describe the Solar System with the Sun as its centre
- understand the difference between a star, that produces its own heat and light, and a planet that does not
- name the eight planets in order of distance from the Sun
- draw the Solar System

Specific Aims	1. DOING SCIENCE & TECHNOLOGY	
	2. KNOWING THE SUBJECT CONTENT & MAKING CONNECTIONS	✓
	3. UNDERSTANDING THE USES OF SCIENCES & INDIGENOUS KNOWLEDGE	

**SCIENCE PROCESS SKILLS**

1. Accessing & recalling Information	✓	7. Raising Questions	✓	13. Interpreting Information	✓
2. Observing	✓	8. Predicting		14. Designing	
3. Comparing		9. Hypothesizing		15. Making/ constructing	
4. Measuring		10. Planning Investigations		16. Evaluating and improving products	
5. Sorting & Classifying		11. Doing Investigations		17. Communicating	
6. Identifying problems & issues		12. Recording Information			



## TOPIC: The Solar System

### B POSSIBLE RESOURCES

For this lesson, you will need:

IDEAL RESOURCES	IMPROVISED RESOURCES
Poster of the Solar System	
Resource 1: How to draw the Solar System	

### C CLASSROOM MANAGEMENT

C

1. Make sure that you are ready and prepared.
2. Write the following question onto the chalkboard before the lesson starts:

What is the name of the star that gives Earth its light and heat?

3. Learners should enter the classroom and answer the question in their workbooks.
4. Discuss the answer with the learners.
5. Write the model answer onto the chalkboard.

*The Sun is the star that gives Earth its heat and light.*

### D ACCESSING INFORMATION

D

1. Write the following onto the chalkboard (always try to do this before the lesson starts):

#### OUR SOLAR SYSTEM

##### THE SUN

1. The Sun is a **star**.
2. It makes its own light and heat like all stars.
3. The Sun is very, very big.
4. It is at the centre of our Solar System.

##### THE PLANETS

1. There are eight planets.
2. The eight planets, starting from closest to the sun are: Mercury, Venus, Earth, Mars, Jupiter, Saturn, Uranus, Neptune.
3. A fun sentence to remember the planets:
4. My Very Elderly Mother Just Served Us Noodles.

2. Explain the following to the learners:
  - a. The Sun makes its own heat and light like all **stars**.
  - b. It burns so brightly you should not look at it.

## TOPIC: The Solar System

- c. The Sun is a big ball of fire.
  - d. It is so big that 1 300 000 (1 million 3 hundred thousand) Earths would fit into the Sun (the Earths would have to be melted).
  - e. The Sun is at the centre of our **Solar System**.
  - f. There are eight **planets**.
  - g. Starting with the planet closest to the Sun, the planets are:  
Mercury, Venus, Earth, Mars, Jupiter, Saturn, Uranus, Neptune.
3. Give learners some time to copy this information into their workbooks.

### Checkpoint 1

Ask the learners the following questions to check their understanding at this point:

- a. What is the difference between a star and a planet?
- b. How many planets are there?

Answers to the checkpoint questions are as follows:

- a. A star makes its own heat and light and a planet does not.
- b. There are 8 planets.

## E

### CONCEPTUAL DEVELOPMENT

1. Put up the poster of the Solar System.
2. Point to the Sun and the eight planets. Name the planets as you point to them (Mercury, Venus, Earth, Mars, Jupiter, Saturn, Uranus, Neptune)
3. Ask learners to look at the poster and answer the following questions (answers are in italics):

- a. How many planets are there? *8*
- b. Can you work out which planet is the Earth? *The third one from the Sun*
- c. How do you know this is the Earth? *You can see the clouds, countries and the oceans*
- d. Do any of the planets look the same? *No*
- e. What is different about the planets? *Colour, size, one has a ring around it*
- f. Which planet is closest to the Sun? *Mercury*
- g. Which planet do you think is the coldest? *Neptune*
- h. Why is it the coldest? *It is the furthest from the Sun*

## TOPIC: The Solar System

4. Complete the following activity with the learners to get them to remember the names of the planets:

Get the class to repeat the fun sentence from their workbook or the chalkboard. When they know the fun sentence, get eight learners to stand in a line in front of the class. Learners then say the fun sentence as you point to each learner in turn as each word is spoken. The first learner will be 'My', the second learner will be 'Very', the third learner will be 'Elderly', and so on. When they are able to do this, get the class to say each planet's name as you point to each of the eight learners. This must always be done in order starting with Mercury.

Ask another eight learners to stand in a line. See if they can remember the fun sentence and then the names of the eight planets. Repeat this with another eight learners.

Fun sentence:

**My Very Elderly Mother Just Served Us Noodles.**

**Mercury Venus Earth Mars Jupiter Saturn Uranus Neptune**

5. Ask learners to open their workbooks. Tell them that they are going to draw the Solar System. They must look carefully at the poster of the Solar System. Look at Resource 1; on 'How to Draw the Solar System'. Do this step-by-step on the chalkboard. The learners must copy what you are doing, step-by-step:
  - a. Draw the Sun and the eight planets (they must try and keep the sizes of the planets relative to each other according to their size).
  - b. Label each planet.
  - c. Give their drawing a title 'The Solar System'.

### **Checkpoint 2**

Ask learners the following questions to check their understanding at this point:

- a. Name all of the planets?
- b. Which star in the Solar System produces heat and light?

Answers to the checkpoint questions are as follows:

- a. Mercury, Venus, Earth, Mars, Jupiter, Saturn, Uranus, Neptune
- b. The Sun

6. Ask the learners if they have any questions and provide answers and explanations.

## TOPIC: The Solar System

### F REFERENCE POINTS FOR FURTHER DEVELOPMENT

If you need additional information or activities on this topic, you can find these in your textbook on the following pages:

NAME OF TEXTBOOK	TOPIC	PAGE NUMBER
Study & Master	The Solar System	139
Viva	The Solar System	152
Platinum	The Solar System	167-168
Solutions for All	The Solar System	252-254
Day-by-Day	The Solar System	152
Oxford	The Solar System	116
Spot On	The Solar System	78
Top Class	The Solar System	122-125
Sasol Inzalo Bk B	The Solar System	94-97; 101-103

### G ADDITIONAL ACTIVITIES / READING

In addition, further reading, listening or viewing activities related to this sub-topic are available through the following web links:

1. <http://www.kidzone.ws/planets/> [Planet Facts]
2. <https://goo.gl/QJjt48> [Tricks to remember the planet's names]

**1 B**

**Term 4, Week 1, Lesson B**

**Lesson Title: The Sun, Planets and Asteroids**

**Time for lesson: 1 hour**

**A POLICY AND OUTCOMES**

<b>Sub-Topic</b>	The Asteroid Belt and more about the Eight Planets
<b>CAPS Page Number</b>	61

**Lesson Objectives**

By the end of the lesson, learners will be able to:

- describe the Solar System with the Sun as its centre
- understand the difference between a star, that produces its own heat and light, and a planet that does not
- name the eight planets in order of distance from the Sun
- draw the Solar System

Specific Aims	1. DOING SCIENCE & TECHNOLOGY	
	2. KNOWING THE SUBJECT CONTENT & MAKING CONNECTIONS	✓
	3. UNDERSTANDING THE USES OF SCIENCES & INDIGENOUS KNOWLEDGE	

**SCIENCE PROCESS SKILLS**

1. Accessing & recalling Information	✓	7. Raising Questions	✓	13. Interpreting Information	✓
2. Observing	✓	8. Predicting		14. Designing	
3. Comparing		9. Hypothesizing		15. Making/ constructing	
4. Measuring		10. Planning Investigations		16. Evaluating and improving products	
5. Sorting & Classifying		11. Doing Investigations		17. Communicating	
6. Identifying problems & issues		12. Recording Information	✓		

## TOPIC: The Solar System

### B POSSIBLE RESOURCES

For this lesson, you will need:

IDEAL RESOURCES	IMPROVISED RESOURCES
Poster of the Solar System	
Resource 2: The Inner and Outer Planets	
Resource 3: Asteroid 243 Ida with a moon called Dactyl	
Resource 4: The Asteroid Belt	

### C CLASSROOM MANAGEMENT

1. Make sure that you are ready and prepared.
2. Write the following question onto the chalkboard before the lesson starts:

Name the eight planets starting with the planet closest to the Sun.

3. Learners should enter the classroom and answer the question in their workbooks.
4. Discuss the answer with the learners.
5. Write the model answer onto the chalkboard.

*Mercury, Venus, Earth, Mars, Jupiter, Saturn, Uranus, Neptune*

### D ACCESSING INFORMATION

1. Write the following onto the chalkboard (always try to do this before the lesson starts):

#### THE INNER ROCKY PLANETS

1. The first four planets are known as the inner, rocky planets.
2. They are the four planets closest to the Sun.
3. They are made mostly from rocks and metal.
4. These planets are Mercury, Venus, Earth and Mars.

#### THE OUTER GAS PLANETS

1. The next four planets are known as the outer, gas planets.
2. They are made up of swirling clouds of gas.
3. They are much bigger than the inner planets.
4. All four gas planets have beautiful rings around them.
5. These rings are made up of small pieces of dust and ice.
6. These planets are Jupiter, Saturn, Uranus and Neptune.

## TOPIC: The Solar System

### THE ASTEROID BELT

1. Asteroids are pieces of rock or metal that orbit the Sun.
  2. They can be as big as a building in a city or as small as a grain of sand.
  3. They group together to form the Asteroid Belt.
  4. This Belt lies between the inner planets and the outer planets.
2. Explain the following to the learners:
    - a. The first four planets closest to the Sun are known as the inner, rocky planets.
    - b. These planets are made up of rocks and metal.
    - c. The next four planets are known as the outer, gas planets.
    - d. These planets are made up mostly of gas.
    - e. Asteroids are pieces of rock and metal that orbit the Sun.
    - f. They can be very big or very small.
    - g. Asteroids have grouped together to form a belt between Mars and Jupiter.
  3. Give learners some time to copy this information into their workbooks.

### **Checkpoint 1**

Ask the learners the following questions to check their understanding at this point:

- a. What are the four inner planets mostly made up of?
- b. Are the outer, gas planets much bigger or much smaller than the inner planets?

Answers to the checkpoint questions are as follows:

- a. Rocks and metal
- b. Much bigger

## **E**

### **CONCEPTUAL DEVELOPMENT**

1. Show learners Resource 2: 'The larger outer planets compared to the smaller inner planets'.
2. Explain the following about Resource 2:
  - a. Part of the Sun can be seen on the left-hand side.
  - b. The first four planets closest to the Sun are the rocky planets.
  - c. These are also known as the inner planets.
  - d. The next four planets are the outer, gas planets.
  - e. Notice the differences in size between the inner planets and the outer planets.

## TOPIC: The Solar System

3. Ask the learners the following questions (answers are in italics):

- a. Why do you think the rocky planets are called the 'inner' planets? (*They are the four closest to the Sun*)
- b. Why are they called the 'rocky' planets? (*They are made from rocks and metal*)
- c. Can you name the four inner rocky planets from left to right? (*Mercury, Venus, Earth, Mars*)
- d. Can you name the four outer gas planets from left to right? (*Jupiter, Saturn, Uranus, Neptune*)
- e. Why are these four planets called the 'gas' planets? (*They are mostly made from gas*)
- f. What star do all these planets orbit around? (*The Sun*)
- g. Which are larger – the inner, rocky planets or the outer, gas planets? (*The outer, gas planets*)
- h. Which is the largest planet? (*Jupiter*)
- i. Which planet is closest to the Sun? (*Mercury*)
- j. Which planet is the furthest from the Sun? (*Neptune*)

4. Show learners the photograph of an **asteroid** (Resource 3: 'Asteroid 243: Ida with a Moon called Dactyl'). Point out all the **craters** on Ida.

5. Explain the following to the learners:

- a. Asteroids are numbered according to the order in which they are discovered.
- b. Ida was the 243rd asteroid to be discovered.
- c. There are many craters on asteroids.
- d. This Asteroid Belt is between the Inner Planets and the Outer Planets. (Show the learners this area on the poster)
- e. It lies between Mars and Jupiter.
- f. Astronomers (scientists who study Space) have identified 26 very large asteroids.
- g. It has been **estimated** that there are 1 100 000 (1,1 million) asteroids in this Belt.

6. Show learners Resource 4. Show the learners that the Asteroid Belt lies between the orbits of Mars and Jupiter.

7. Tell the learners to do the following:

- a. Turn back to the drawing of the Solar System done in Lesson 1.
- b. Draw in the Asteroid Belt.
- c. The Asteroid Belt must be between the orbit of Mars and the orbit of Jupiter.



## TOPIC: The Solar System

### **Checkpoint 2**

Ask the learners the following questions to check their understanding at this point:

- a. Name the four inner, rocky planets.
- b. The Asteroid Belt is between the orbit of two planets. Name these planets.

Answers to the checkpoint questions are as follows:

- a. Mercury, Venus, Earth, Mars
- b. Mars and Jupiter

8. Ask the learners if they have any questions and provide answers and explanations.

## **F**

### **REFERENCE POINTS FOR FURTHER DEVELOPMENT**

If you need additional information or activities on this topic, you can find these in your textbook on the following pages:

NAME OF TEXTBOOK	TOPIC	PAGE NUMBER
Study & Master	The Solar System	140
Viva	The Solar System	152
Platinum	The Solar System	168-169
Solutions for All	The Solar System	252-254
Day-by-Day	The Solar System	153
Oxford	The Solar System	-
Spot On	The Solar System	79-181
Top Class	The Solar System	123
Sasol Inzalo Bk B	We visit the eight planets; Asteroids	107-109; 119-120

## **G**

### **ADDITIONAL ACTIVITIES / READING**

In addition, further reading, listening or viewing activities related to this sub-topic are available through the following web links:

1. <http://easyscienceforkids.com/inner-and-outer-planets/> [Inner and Outer Planets]
2. <https://goo.gl/ZdU6Jp> [Inner versus Outer Planets]
3. <https://goo.gl/AKCNvA> (6mins) [Space: The Rocky and Gas Planets]

## TOPIC: The Solar System

# 1 C

### Term 4, Week 1, Lesson C

### Lesson Title: The Sun, Planets and Asteroid

### Time for lesson: 1½ hours

#### A POLICY AND OUTCOMES

<b>Sub-Topic</b>	s The Rocky Planets
<b>CAPS Page Number</b>	61

#### Lesson Objectives

By the end of the lesson, learners will be able to:

- name the four rocky planets
- describe the features of the rocky planets

Specific Aims	1. DOING SCIENCE & TECHNOLOGY	
	2. KNOWING THE SUBJECT CONTENT & MAKING CONNECTIONS	✓
	3. UNDERSTANDING THE USES OF SCIENCES & INDIGENOUS KNOWLEDGE	

#### SCIENCE PROCESS SKILLS

1. Accessing & recalling Information	✓	7. Raising Questions		13. Interpreting Information	✓
2. Observing	✓	8. Predicting		14. Designing	
3. Comparing		9. Hypothesizing		15. Making/ constructing	
4. Measuring		10. Planning Investigations		16. Evaluating and improving products	
5. Sorting & Classifying	✓	11. Doing Investigations		17. Communicating	✓
6. Identifying problems & issues		12. Recording Information			

## TOPIC: The Solar System

### B POSSIBLE RESOURCES

For this lesson, you will need:

IDEAL RESOURCES	IMPROVISED RESOURCES
Resource 2: The larger outer planets compared to the smaller inner planets	
Resource 5: The Four Rocky Planets	
Resource 7: Compare sizes: Venus and Earth	

### C CLASSROOM MANAGEMENT

1. Make sure that you are ready and prepared.
2. Write the following question onto the chalkboard before the lesson starts:

What is the Asteroid Belt?

3. Learners should enter the classroom and answer the question in their workbooks.
4. Discuss the answer with the learners.
5. Write the model answer onto the chalkboard.

*A group of asteroids between the inner and outer planets (or between Mars and Jupiter, or between the rocky and gas planets).*

### D ACCESSING INFORMATION

1. Write the following onto the chalkboard (always try to do this before the lesson starts):

#### THE FOUR ROCKY PLANETS

##### MERCURY

1. Mercury is the closest planet to the Sun.
2. It is the fastest planet and the smallest planet.
3. It has no atmosphere and so gets very cold and very hot.
4. Its surface is grey with many craters.

##### VENUS

1. Venus is about the same size as Earth.
2. Venus shines brightly in the night sky.
3. It has a thick cloud of gas around it.
4. Venus does not have craters because rocks cannot get through this thick cloud of gas.
5. It is the hottest planet and has an average temperature of 464°C.

## TOPIC: The Solar System

### EARTH

1. Earth is the largest of the four inner planets.
2. It has large amounts of water on it so it looks blue from Space.
3. It is the only planet we know of that supports life.
4. Its atmosphere has oxygen that animals take in and carbon dioxide that plants take in.
5. Earth has one moon.

### MARS

1. It is also known as the Red Planet as it has red dust that covers its surface.
2. The surface is a rocky desert with volcanoes and valleys.
3. It has large dust storms.
4. It is a cold and windy planet.
5. Mars has two small moons.

2. Explain Mercury and Venus to learners as follows:
  - a. Show them Mercury on Resource 2: 'The larger outer planets compared to the smaller inner planets' (Mercury is the closest planet to the Sun).
  - b. Mercury is the closest planet to the Sun but it is not the hottest planet as it has no **atmosphere**. It gets very hot on the side facing the Sun and very cold on the other side.
  - c. The surface of Mars is grey and has many craters. Show learners Resource 5: "Mercury's Surface".
  - d. Rocks crash into Mercury as it has no atmosphere. It therefore has many craters.
  - e. Venus is about the same size as Earth. Show learners Resource 7: Compare sizes: Venus and Earth.
  - f. Venus shines nearly as brightly as our Moon, either in the evening or the morning. Show learners Resource 8: Venus, the bright planet in the night sky.
  - g. Venus has a thick atmosphere of poisonous gas - we could not live there.
  - h. Because of its atmosphere and its closeness to the Sun, Venus is the hottest planet in our Solar system. (Mercury is closer to the sun but it has no atmosphere).
  - i. The temperature on Venus is the same during the night and the day.
3. Give learners some time to copy the information about Mercury and Venus from the chalkboard into their workbooks.
4. Explain the following about Earth and Mars to learners:
  - a. Show learners Earth on the diagram from Resource 2 (The larger outer planets compared to the smaller inner planets).
  - b. Earth is known as the Blue Planet as it looks blue from Space.
  - c. The Earth has one moon.
  - d. The Moon orbits the Earth.

## TOPIC: The Solar System

- e. Mars is known as the Red Planet as it is covered in red dust.
  - f. It is colder than Earth as it is further from the Sun than Earth.
5. Give learners some time to copy the information about Earth and Mars into their workbooks.

### **Checkpoint 1**

Ask the learners the following questions to check their understanding at this point:

- a. Why is Venus the hottest planet?
- b. Why is Mars known as the Red Planet?

Answers to the checkpoint questions are as follows:

- a. Mercury has no atmosphere and so gets very cold and very hot. Venus has a thick cloud of gas surrounding it and it is the next closest planet to the Sun.
- b. Mars is covered in red dust.

## **E**

### **CONCEPTUAL DEVELOPMENT**

1. Go outside with the class. Ask five learners to stand in a line, about a metre apart. The first learner will represent the Sun and stand still. The second learner will represent Mercury, the third Venus, the fourth Earth and the fifth Mars. Get the learners representing the planets to walk around the Sun at the same pace in a circle. Point out the following:
  - a. Mercury is closest to the Sun so it orbits the Sun in the shortest time.
  - b. It has no atmosphere so the side facing the Sun will be very hot and the other side will be very cold.
  - c. Venus is the hottest planet as it has a thick layer of gas surrounding it and it is second closest to the Sun.
  - d. Earth has an atmosphere.
  - e. Earth gets its light and heat from the Sun.
  - f. Mars is the furthest of these four planets from the Sun.
  - g. Mars takes nearly twice as long to orbit the Sun compared to the Earth (the learners representing the Earth and Mars must walk around the learner representing the Sun at the same pace to demonstrate this).
  - h. Mars is the coldest of these four planets as it is the furthest from the Sun.
2. Back in the classroom, show learners Resource 5: "The Four Rocky Planets". Ask them to look at the image carefully.
3. Ask learners the following questions (answers are in italics):

## TOPIC: The Solar System

- a. What are these four planets made of? (*They are mostly made from rocks and metal*)
- b. Which is the hottest planet? (*Venus*)
- c. Why is it the hottest planet? (*Mercury, the closest planet to the Sun, has no atmosphere and is very cold or very hot. Venus is the second closest to the Sun and has a thick atmosphere which traps the heat from the Sun.*)
- d. What do we call the dents made from rocks crashing into a planet? (*Craters*)
- e. Which planet is almost the same size as Earth? (*Venus*)
- f. Which planet is known as the 'Blue Planet'? (*Earth*)
- g. Which is the coldest planet out of the rocky planets? (*Mars*)
- h. Why is it colder than Earth? (*it is further from the Sun*)

4. Read the following to the class:

There are some people who dream about going to live on Mars one day. The Mars One mission is selecting people who are interested in making the first human settlement on Mars. Six groups of four people will be chosen to go and live on Mars. A scientist from Durban has made it onto the final 100 list. Her name is Adriana Marais. The trip is planned for 2024. It will take them seven to eight months to get to Mars. A company owned by Elon Musk, another South African living in the USA, might build the rocket that will take the settlers to Mars.

5. Show learners Resource 10: "Mars". Adriana Marais is a South African who is on the final list of 100 people chosen to possibly go to Mars. The rocket is designed and made by Elon Musk's company in the USA. This rocket might be selected to take the journey to Mars.
6. Ask learners to discuss the following with another learner and to write their answers in their workbooks:
  - a. What sort of a person would you have to be to travel with three other people in a rocket for eight months?
  - b. What do you think they will have to do when they get there?

Possible responses are:

- a. Patient, friendly, easy-going, strong, brave person.
- b. They will have to wear astronaut suits with helmets and carry oxygen so that they can breathe. They will have to build an enclosed structure to live in.

## TOPIC: The Solar System

### **Checkpoint 2**

Ask the learners the following questions to check their understanding at this point:

- a. Which planet supports life?
- b. Which planet do people want to go and live on?

Answers to the checkpoint questions are as follows:

- a. Earth
- b. Mars

7. Ask the learners if they have any questions and provide answers and explanations.

## **F** REFERENCE POINTS FOR FURTHER DEVELOPMENT

If you need additional information or activities on this topic, you can find these in your textbook on the following pages:

NAME OF TEXTBOOK	TOPIC	PAGE NUMBER
Study & Master	The Solar System	141-143
Viva	The Solar System	154-156
Platinum	The Solar System	170-171
Solutions for All	The Solar System	256-257
Day-by-Day	The Solar System	154-155
Oxford	The Solar System	117
Spot On	The Solar System	79-80
Top Class	The Solar System	124-125
Sasol Inzalo Bk B	We visit the eight planets	107-108; 110 - 113

## **G** ADDITIONAL ACTIVITIES / READING

In addition, further reading, listening or viewing activities related to this sub-topic are available through the following web links:

1. <https://goo.gl/iu9Jo3> (11 mins) [Dr Adriana Marais]
2. <https://goo.gl/SnvSkB> (3 mins) [Venus]

## TOPIC: The Solar System

# 2 A

### Term 4, Week 2, Lesson A

### Lesson Title: Sun, Planets and Asteroids

### Time for lesson: 1 hour

## A

### POLICY AND OUTCOMES

<b>Sub-Topic</b>	The Gas Planets
<b>CAPS Page Number</b>	61

#### Lesson Objectives

By the end of the lesson, learners will be able to:

- name the four gas planets
- describe their features

Specific Aims	1. DOING SCIENCE & TECHNOLOGY	
	2. KNOWING THE SUBJECT CONTENT & MAKING CONNECTIONS	✓
	3. UNDERSTANDING THE USES OF SCIENCES & INDIGENOUS KNOWLEDGE	

### SCIENCE PROCESS SKILLS

1. Accessing & recalling Information	✓	7. Raising Questions	✓	13. Interpreting Information	✓
2. Observing	✓	8. Predicting	✓	14. Designing	
3. Comparing	✓	9. Hypothesizing		15. Making/ constructing	
4. Measuring		10. Planning Investigations		16. Evaluating and improving products	
5. Sorting & Classifying		11. Doing Investigations		17. Communicating	✓
6. Identifying problems & issues		12. Recording Information			



## TOPIC: The Solar System

### B POSSIBLE RESOURCES

For this lesson, you will need:

IDEAL RESOURCES	IMPROVISED RESOURCES
Poster: The Solar System	
Resource 2: Diagram of the larger outer planets and the smaller inner planets	
Resource 9: The Four Gas Planets	

### C CLASSROOM MANAGEMENT

1. Make sure that you are ready and prepared.
2. Write the following question onto the chalkboard before the lesson starts:

Name the four inner rocky planets.

3. Learners should enter the classroom and answer the question in their workbooks.
4. Discuss the answer with the learners.
5. Write the model answer onto the chalkboard.

*Mercury, Venus, Earth, Mars*

### D ACCESSING INFORMATION

1. Write the following onto the chalkboard (always try to do this before the lesson starts):

#### THE FOUR GAS PLANETS

##### JUPITER

1. Jupiter is the largest planet.
2. It has strong winds.
3. These winds blow the gases and this makes the planet look streaky.
4. 69 moons have been discovered but there may be more.
5. It is a cold planet with an average temperature of  $-110^{\circ}\text{C}$ .

##### SATURN

1. Saturn has seven rings around it.
2. It has 62 moons.

## TOPIC: The Solar System

### URANUS

1. Uranus is a frozen gas planet.
2. Its average temperature is  $-195^{\circ}\text{C}$ .
3. It looks as if it is leaning over - it has a tilted axis.
4. It has nine dark rings and two light rings.
5. There are 27 moons.
6. It orbits the Earth every 84 Earth years.

### NEPTUNE

1. Neptune is also a frozen gas planet.
2. It is a very cold planet with an average temperature of  $-214^{\circ}\text{C}$ .
3. It also has very fast winds.
4. It has a blue-green colour.

2. Show learners Resource 2: The larger outer planets compared to the smaller inner planets.
3. Explain about Jupiter and Saturn as follows:
  - a. Show the learners planet Jupiter on the diagram in Resource 2 (It is the fifth planet from the Sun).
  - b. Jupiter is the largest planet.
  - c. Jupiter can fit 1 400 (one thousand four hundred) Earths inside (these Earths would have to be melted).
  - d. Jupiter has very strong winds that blow the gases. This makes the planet look streaky (get learners to look at Resource 10: Jupiter).
  - e. 69 moons have been discovered orbiting Jupiter but there may still be more.
  - f. Show learners Saturn on the diagram in Resource 2 (It is the sixth planet, with rings).
  - g. Saturn has seven rings made up of gas and ice (Show learners Resource 11: Saturn).
  - h. Like Jupiter, Saturn has many moons.
  - i. Saturn has 62 moons.
4. Give learners some time to copy this information about Jupiter and Saturn into their workbooks.

## TOPIC: The Solar System

5. Explain Uranus and Neptune to the learners as follows:
  - a. Show learners Uranus on the Diagram from Resource 2 (Uranus is the seventh planet from the Sun).
  - b. Uranus and Neptune are frozen gas planets.
  - c. They are both very cold.
  - d. Uranus has a tilted axis – it looks as if it is leaning over.
  - e. It has 11 rings surrounding it.
  - f. 27 moons orbit Uranus.
  - g. Neptune is the furthest planet from the Sun.
  - h. It takes a long time to orbit the Sun.
  - i. Neptune has very fast winds.
  - j. It has 14 moons and 6 dark rings.
6. Give learners some time to copy this information about Uranus and Neptune into their workbooks.

### **Checkpoint 1**

Ask the learners the following questions to check their understanding at this point:

- a. Name the four gas planets.
- b. Which planet has the most moons?

Answers to the checkpoint questions are as follows:

- a. Jupiter, Saturn, Uranus, Neptune
- b. Jupiter

## **E**

### **CONCEPTUAL DEVELOPMENT**

1. Show learners Resource 9: "The Four Gas Planets". Ask them to look at the image carefully.
2. Ask learners the following (answers are in italics):

- a. What are these four planets made of? (*They are made of gas*)
- b. Which is the coldest planet? (*Neptune*)
- c. Why is Neptune the coldest planet? (*It is the furthest from the Sun*)
- d. Which planet has the most moons? (*Jupiter*)
- e. What are Neptune and Uranus made up of? (*Frozen gas*)
- f. Which planet is tilted on its axis? (*Uranus*)
- g. Which is the largest planet? (*Jupiter*)

## TOPIC: The Solar System

3. Give the following activity to the class. This is a cloze activity. Write the sentences and the words on the chalkboard. Learners must copy the paragraph and choose the correct word from the given list to fill in the spaces. Learners must underline the words that they have filled in.

1. Saturn is the sixth planet from the Sun but it is the second \_\_\_\_\_ planet.
2. \_\_\_\_\_ is the furthest planet from the Sun.
3. Jupiter is the largest planet in our \_\_\_\_\_ .
4. Jupiter, Saturn, Uranus and Neptune are the \_\_\_\_\_ gas planets.
5. These four planets are made mostly of \_\_\_\_\_ .
6. All of these gas planets are surrounded by \_\_\_\_\_ .

**Words to choose from:**

gas, largest, Solar System, Neptune, four, rings

Answer:

1. Saturn is the sixth planet from the Sun but it is the second largest planet.
2. Neptune is the furthest planet from the Sun.
3. Jupiter is the largest planet in our Solar System.
4. Jupiter, Saturn, Uranus and Neptune are the four gas planets.
5. These four planets are made mostly of gas.
6. All of these gas planets are surrounded by rings.

4. If time allows, do the following activity:

Tell the learners that you are going to play the following game. Ask learners to listen to the clues and then write down the planet being described from the clues. Answers are in italics after the clues. Read out all four sets of clues before giving any answers.

What Planet am I?

- a. I am a gas planet.  
I am also an outer planet.  
I am made from frozen gas.  
I am the planet furthest from the Sun.  
I am the coldest planet.  
(*Neptune*)

## TOPIC: The Solar System

- b. I am a gas planet.  
I am an outer planet.  
I have a tilted axis.  
My average temperature is  $-195^{\circ}\text{C}$ .  
I have 27 moons.  
(*Uranus*)
- c. I am a gas planet.  
I am an outer planet.  
I am the largest planet in the Solar System.  
Strong winds blow my gases which gives me a streaky appearance.  
I have the most moons of all the planets.  
(*Jupiter*)
- d. I am a gas planet.  
I am an outer planet.  
I have 7 rings and 62 moons.  
(*Saturn*)

### **Checkpoint 2**

Ask the learners the following questions to check their understanding at this point:

- a. Which is the largest planet?
- b. Which two planets are made from frozen gas?

Answers to the checkpoint questions are as follows:

- a. Jupiter
- b. Uranus and Neptune

5. Ask the learners if they have any questions and provide answers and explanations.

## TOPIC: The Solar System

### F REFERENCE POINTS FOR FURTHER DEVELOPMENT

If you need additional information or activities on this topic, you can find these in your textbook on the following pages:

NAME OF TEXTBOOK	TOPIC	PAGE NUMBER
Study & Master	The Solar System	143-144
Viva	The Solar System	154-157
Platinum	The Solar System	173
Solutions for All	The Solar System	256-259
Day-by-Day	The Solar System	154-155
Oxford	The Solar System	118
Spot On	The Solar System	80-81
Top Class	The Solar System	125
Sasol Inzalo Bk B	The Gas Planets	109; 114 - 118

### G ADDITIONAL ACTIVITIES/ READING

In addition, further reading, listening or viewing activities related to this sub-topic are available through the following web links:

1. <https://goo.gl/h9bAcV> [Gas Giant Planets: Quiz]
2. <https://goo.gl/C7V1Xu> (6 ½ mins) [Outer Planets of the Solar System]

**2 B**

Term 4, Week 2, Lesson B

Lesson Title: The Sun, Planets and Asteroids

Time for lesson: 1½ hours

**A POLICY AND OUTCOMES**

<b>Sub-Topic</b>	Distances from the Sun
<b>CAPS Page Number</b>	61

**Lesson Objectives**

By the end of the lesson, learners will be able to:

- Compare each planet's distance from the Sun
- Make a model of the Solar System to show relative distances of the planets from the Sun and each other

Specific Aims	1. DOING SCIENCE & TECHNOLOGY	✓
	2. KNOWING THE SUBJECT CONTENT & MAKING CONNECTIONS	✓
	3. UNDERSTANDING THE USES OF SCIENCES & INDIGENOUS KNOWLEDGE	

**SCIENCE PROCESS SKILLS**

1. Accessing & recalling Information	✓	7. Raising Questions		13. Interpreting Information	✓
2. Observing		8. Predicting		14. Designing	
3. Comparing		9. Hypothesizing		15. Making/ constructing	✓
4. Measuring	✓	10. Planning Investigations		16. Evaluating and improving products	
5. Sorting & Classifying		11. Doing Investigations	✓	17. Communicating	
6. Identifying problems & issues		12. Recording Information	✓		

## TOPIC: The Solar System

### B POSSIBLE RESOURCES

For this lesson, you will need:

IDEAL RESOURCES	IMPROVISED RESOURCES
Poster of the Solar System	
Resource 4: The Asteroid Belt	
Strip of paper (1m long and 5cm – 10 cm wide), if possible get one strip for each pair of learners	
10 pieces of paper	

### C CLASSROOM MANAGEMENT

1. Make sure that you are ready and prepared.
2. Write the following question onto the chalkboard before the lesson starts:

Why is Neptune the coldest planet?

3. Learners should enter the classroom and answer the question in their workbooks.
4. Discuss the answer with the learners.
5. Write the model answer onto the chalkboard.

*It is the furthest planet from the Sun.*

### D ACCESSING INFORMATION

1. Draw the following table onto the chalkboard (always try to do this before the lesson starts):

PLANET	What is it made of?	Number of rings	Number of moons	Temp	Distance from the Sun
Mercury	rock	0	0	167°C	60 million km
Venus	rock	0	0	464°C	108 million km
Earth	rock	0	1	15°C	150 million km
Mars	rock	0	2	-65°C	228 million km
Jupiter	gas	3	67	-110°C	779 million km
Saturn	gas	7	62	-140°C	1434 million km
Uranus	frozen gas	11	27	-195°C	2873 million km
Neptune	frozen gas	6	14	-200°C	4495 million km



## TOPIC: The Solar System

2. Explain to the learners how the temperatures on the planets get lower the further the planets are from the Sun, except for Mercury and Venus. Use the poster of the Solar System to assist with the explanation.
  - a. Mercury does not have an atmosphere and therefore the side facing the Sun gets very hot and the opposite side gets very cold.
  - b. Venus has a thick layer of poisonous gas surrounding it and is therefore very, very hot.
3. Explain that distances in Space are very big. The poster of the Solar System does not show the distances of the planets from the Sun. The poster shows the order of the planets and their sizes.
4. Give learners some time to copy this table into their workbooks.

### **Checkpoint 1**

Ask the learners the following questions to check their understanding at this point:

- a. Which planet is closest to the Sun?
- b. How far is Earth from the Sun? Read your answer from the table.

Answers to the checkpoint questions are as follows:

- a. Mercury
- b. 150 million km (150 000 000 km)

## **E**

### **CONCEPTUAL DEVELOPMENT**

1. Get 10 pieces of paper. On one piece of paper write 'Sun'. On eight pieces of paper write the names of the eight planets (Mercury, Venus, Earth, Mars, Jupiter, Saturn, Uranus, Neptune). On the 10th piece of paper write 'The Asteroid Belt'. Go outside with the class. Find a large area.
2. Explain that they are now going to find out how far each planet is from the Sun. Each step they take is equal to 60 000 000 (60 million) kilometres.
3. Choose 10 learners. Each learner must have the relevant piece of paper with the name of the planet they are representing. Do the following:
  - a. Let one learner represent the Sun. This learner must stand in the middle of the area. The learner must hold up the piece of paper saying 'Sun'.
  - b. A second learner will represent Mercury. This learner must take 1 step from the Sun. Explain that 1 step = 60 million kilometres (the same as going around the Earth 4 600 times). Get the learner to hold up the piece of paper with 'Mercury' on it.
  - c. A third learner will represent Venus. This learner must take 2 steps from the Sun and hold up the piece of paper with 'Venus' written on it.

## TOPIC: The Solar System

- d. Earth must take 2 ½ steps from the Sun and hold up the correct piece of paper.
  - e. Mars must take 4 steps.
  - f. The Asteroid Belt must take 8 steps.
  - g. Jupiter must take 13 steps.
  - h. Saturn must take 24 steps.
  - i. Uranus must take 49 steps.
  - j. Neptune must take 76 steps.
4. Ask learners to look at the distances that the planets are from each other and to notice how far away Neptune is from the Sun.
  5. Explain to learners that if they travelled in a rocket to Mars from Earth, it would take them 7 to 8 months. If they were to travel to Neptune, it would take them 5 ¼ years! Neptune is very, very far from the Sun and the Earth.
  6. Ask learners the following questions (answers are in italics):

- a. Look at the distances between the inner planets and the distances between the outer planets. What do you notice? *The inner planets are closer together and the outer planets have big distances between them.*
- b. Which planet is furthest from the Sun? *Neptune*
- c. Which planet is closest to the Sun? *Mercury*
- d. Why is Neptune the coldest planet? *It is the furthest from the Sun*
- e. Between which two planets does the Asteroid Belt lie? *Mars and Jupiter*

7. Go back into the classroom. Complete the following activity with learners either by demonstrating with one learner, or if you have enough resources, let learners work in pairs.

- a. On a strip of paper, label the Sun on the left side and Pluto (a dwarf planet found after Neptune) on the right side.
- b. Fold the paper in half. Draw a black line on the fold mark. Write 'Uranus' along the line.

<b>Sun</b>	<b>Uranus</b>	<b>Pluto</b>
<ol style="list-style-type: none"> <li>c. Fold 'Pluto' onto 'Uranus'. Draw a black line on the fold mark. Write 'Neptune' on this line.</li> <li>d. Fold 'Sun' onto 'Uranus'. Draw a black line on the fold mark. Write 'Saturn' on this line.</li> </ol>		

## TOPIC: The Solar System

<b>Sun</b>	<b>Saturn</b>	<b>Uranus</b>	<b>Neptunes</b>	<b>Pluto</b>		
<p>e. Fold 'Sun' onto 'Saturn'. Draw a black line on the fold mark. Write 'Jupiter' on this line.</p> <p>f. Fold 'Sun' onto 'Jupiter'. Draw a black line on the fold mark. Write 'Asteroid Belt' on the line.</p>						
<b>Sun</b>	<b>Asteroid Belt</b>	<b>Jupiter</b>	<b>Saturn</b>	<b>Uranus</b>	<b>Neptunes</b>	<b>Pluto</b>
<p>g. Fold 'Sun' onto 'Asteroid Belt'. Draw a black line on the fold mark. Write 'Mars' on the line.</p> <p>h. Fold 'Sun' onto 'Mars'. Fold the paper one more time. There should now be three fold lines between the 'Sun' and 'Mars'. Draw black lines on the fold lines. Label these, starting with closest to the 'Sun': 'Mercury', 'Venus' and 'Earth'.</p>						
<b>Sun</b>	<b>Mercury</b>	<b>Venus</b>	<b>Earth</b>	<b>Mars</b>	<b>Asteroid Belt</b>	
<p>i. Examine the strip of paper. (For a video demonstration on how to make a Pocket Solar System go to <a href="https://goo.gl/f4WNt5">https://goo.gl/f4WNt5</a>)</p>						

8. Ask learners the following question about the strip of paper with the Solar System:  
What do you notice about the inner planets compared to the outer planets? (*The inner planets are close together. There is a lot of space between the outer planets*)
9. Explain to learners that the furthest humans have travelled is to Earth's moon. However, rockets have gone to Mars.
10. Explain to learners that we can see Venus in the night sky. It is known as the Evening Star. It shines brightly. It is brighter than Jupiter, as it is closer to Earth. Look at the distances on your strip of paper. (See Resource 8: Venus: the bright planet in the night sky).

## TOPIC: The Solar System

### **Checkpoint 2**

Ask the learners the following questions to check their understanding at this point:

- a. Which planet is halfway between the Sun and Uranus? (They can look at the strip of paper)
- b. Which group of planets are closer together – the inner planets or the outer planets?

Answers to the checkpoint questions are as follows:

- a. Saturn
- b. The inner planets

11. Ask the learners if they have any questions and provide answers and explanations.

## **F** REFERENCE POINTS FOR FURTHER DEVELOPMENT

If you need additional information or activities on this topic, you can find these in your textbook on the following pages:

NAME OF TEXTBOOK	TOPIC	PAGE NUMBER
Study & Master	The Solar System	141-144
Viva	The Solar System	156
Platinum	The Solar System	170-171
Solutions for All	The Solar System	-
Day-by-Day	The Solar System	154
Oxford	The Solar System	-
Spot On	The Solar System	81
Top Class	The Solar System	125
Sasol Inzalo Bk B	The Solar System	-

## **G** ADDITIONAL ACTIVITIES / READING

In addition, further reading, listening or viewing activities related to this sub-topic are available through the following web links:

1. <https://goo.gl/QvfN8h> (7 ½ mins) [Planets in our Solar System]

**A**

**POLICY AND OUTCOMES**

<b>Sub-Topic</b>	The Planets and their Orbits
<b>CAPS Page Number</b>	61

**Lesson Objectives**

By the end of the lesson, learners will be able to:

- compare the orbits of the planets
- explain the concept of gravity

Specific Aims	1. DOING SCIENCE & TECHNOLOGY	✓
	2. KNOWING THE SUBJECT CONTENT & MAKING CONNECTIONS	✓
	3. UNDERSTANDING THE USES OF SCIENCES & INDIGENOUS KNOWLEDGE	

**SCIENCE PROCESS SKILLS**

1. Accessing & recalling Information	✓	7. Raising Questions	✓	13. Interpreting Information	✓
2. Observing	✓	8. Predicting	✓	14. Designing	
3. Comparing		9. Hypothesizing		15. Making/ constructing	
4. Measuring		10. Planning Investigations		16. Evaluating and improving products	
5. Sorting & Classifying		11. Doing Investigations	✓	17. Communicating	✓
6. Identifying problems & issues		12. Recording Information	✓		

## TOPIC: The Solar System

### B POSSIBLE RESOURCES

For this lesson, you will need:

IDEAL RESOURCES	IMPROVISED RESOURCES
Poster of the Solar System	
Resource 4: The Asteroid Belt	
A ball, a piece of string about 3 metres in length, a plastic bag, four elastic bands	

### C CLASSROOM MANAGEMENT

1. Make sure that you are ready and prepared.
2. Write the following question onto the chalkboard before the lesson starts:

Which group of planets have bigger distances between them – the inner planets or the outer planets?

3. Learners should enter the classroom and answer the question in their workbooks.
4. Discuss the answer with the learners.
5. Write the model answer onto the chalkboard.

*The outer planets.*

### D ACCESSING INFORMATION

1. Write the following information and draw the table onto the chalkboard (always try to do this before the lesson starts):

1. The Earth orbits the Sun.
2. It takes 365  $\frac{1}{4}$  days for the Earth to orbit the Sun once.
3. The other planets also orbit the Sun.
4. The planets closer to the Sun travel the fastest.

## TOPIC: The Solar System

PLANETS AND THE ASTEROID BELT	HOW LONG IT TAKES TO ORBIT THE SUN (IN EARTH TIME)
Mercury	88 days
Venus	225 days
Earth	365 $\frac{1}{4}$ days
Mars	687 days
Asteroid Belt	3 to 6 years
Jupiter	12 years
Saturn	29 years
Uranus	84 years
Neptune	164 years

2. Explain the following to the learners:
  - a. The Earth takes 365  $\frac{1}{4}$  days to orbit the Sun. This is called an 'Earth year'.
  - b. All the planets in our Solar System orbit the Sun. Mercury is the closest planet to the Sun so it takes the shortest amount of time to orbit the Sun.
  - c. Neptune is the furthest planet from the Sun. It takes a long, long time for Neptune to orbit the Sun. It takes 164 Earth years.
3. Give learners time to copy the above table into their workbooks.

### **Checkpoint 1**

Ask the learners the following questions to check their understanding at this point:

- a. Which planets orbit the Sun?
- b. Which planet takes the longest time to orbit the Sun?

Answers to the checkpoint questions are as follows:

- a. All of the planets in our solar system
- b. Neptune

### **E** CONCEPTUAL DEVELOPMENT

1. Activity: Learners to go outside. You will need the ball, the plastic bag, four elastic bands and a long piece of strong string. Put the ball in the plastic bag. Tie the elastic bands to the handle of the plastic bag. Tie the string to the elastic bands. Ask two learners to do the following:
  - a. One learner will represent the Sun and stand in the middle, holding the end of the string.
  - b. The second learner will run with the ball to help get it going around. The first learner will swing the ball as fast as possible.
  - c. The rest of the class must watch the plastic bag and the elastic bands.
  - d. Learners must observe the elastic bands stretching.

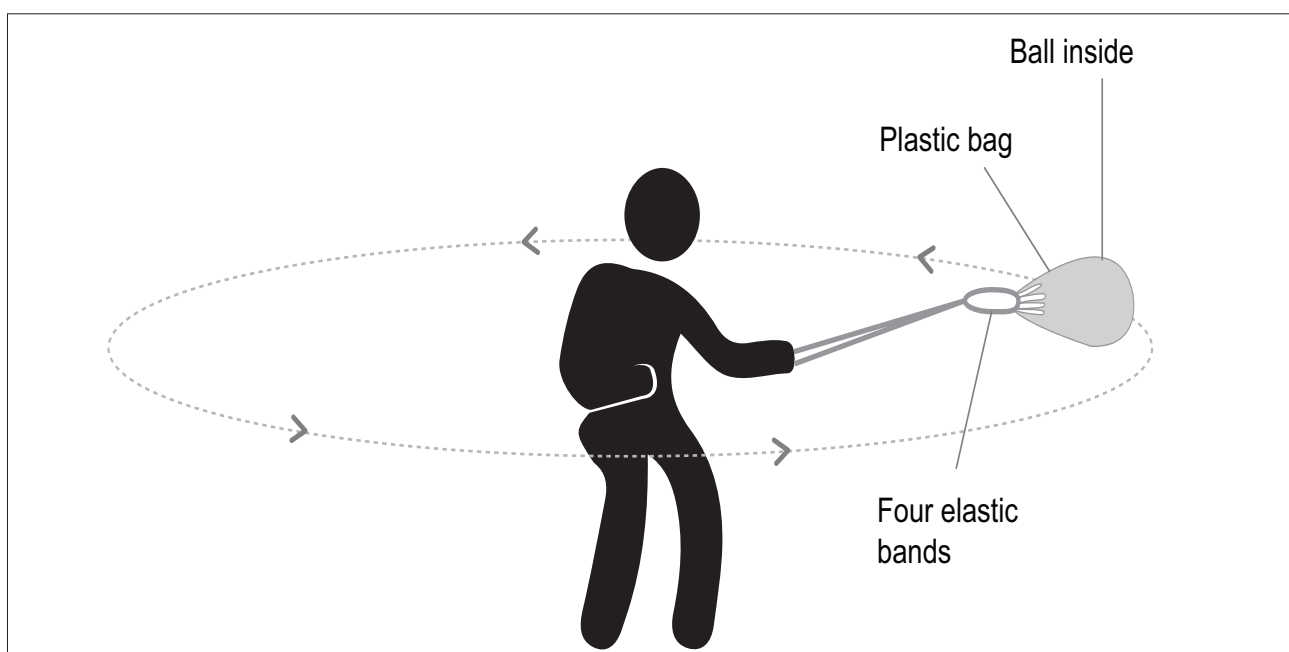

2. Ask learners the following questions:
  - a. What does the learner in the middle represent? *The Sun*
  - b. What does the ball represent? *A planet*
  - c. If the string were to break, what would happen to the ball? *It would go flying off in a straight line*
3. Explain the following to the learners:
  - a. There is no string keeping Earth attached to the Sun.
  - b. The Sun keeps the Earth revolving around it by a force known as gravity.
  - c. If there was no gravity, the Earth would fly off in a straight line like the ball.
  - d. The piece of string represents the force of gravity.
  - e. All planets orbit the Sun.
  - f. All planets are pulled by the Sun's gravity.



## TOPIC: The Solar System

4. Tell learners to look at the table they copied into their workbooks. Ask them the following:
  - a. Which planet takes the shortest time to orbit the Sun? *Mercury*
  - b. Why is this? *It is closest to the Sun and therefore has the shortest path to travel*
  - c. Which planet takes the longest time to orbit the Sun? *Neptune*
  - d. Why is this? *It is the furthest planet from the Sun*
  - e. How many Earth years does it take for Neptune to orbit the Sun? *164 Earth years*
5. Explain to the learners that:
  - a. If they live to 82 years of age, Neptune will only have had two seasons; for example, summer and autumn.
  - b. If they lived on Mercury, they would have four birthdays every Earth year.

### **Checkpoint 2**

Ask the learners the following questions to check their understanding at this point:

- a. How long does it take for the Earth to orbit the Sun?
- b. What force keeps the planets in their orbit around the sun?

Answers to the checkpoint questions are as follows:

- a. 365  $\frac{1}{4}$  days
- b. gravity

6. Ask the learners if they have any questions and provide answers and explanations.

## TOPIC: The Solar System

### F REFERENCE POINTS FOR FURTHER DEVELOPMENT

If you need additional information or activities on this topic, you can find these in your textbook on the following pages:

NAME OF TEXTBOOK	TOPIC	PAGE NUMBER
Study & Master	The Solar System	141-144
Viva	The Solar System	156
Platinum	The Solar System	170-172
Solutions for All	The Solar System	262-263
Day-by-Day	The Solar System	154
Oxford	The Solar System	118
Spot On	The Solar System	79
Top Class	The Solar System	125
Sasol Inzalo	The Solar System	101 - 102

### G ADDITIONAL ACTIVITIES/ READING

In addition, further reading, listening or viewing activities related to this sub-topic are available through the following web links:

1. <https://goo.gl/k2EqAa> (1 ½ min) [Orbit]

**3 A**

**Term 4, Week 3, Lesson A**

**Lesson Title: Moons**

**Time for lesson: 1 hour**

**A POLICY AND OUTCOMES**

<b>Sub-Topic</b>	The Moon
<b>CAPS Page Number</b>	61

**Lesson Objectives**

By the end of the lesson, learners will be able to:

- draw up a table with the number of moons for each planet
- describe how the Moon gets its light
- understand that there is no water, air, wind or rain on the Moon
- describe the first landing on the Moon

Specific Aims	1. DOING SCIENCE & TECHNOLOGY	
	2. KNOWING THE SUBJECT CONTENT & MAKING CONNECTIONS	✓
	3. UNDERSTANDING THE USES OF SCIENCES & INDIGENOUS KNOWLEDGE	

**SCIENCE PROCESS SKILLS**

1. Accessing & recalling Information	✓	7. Raising Questions	✓	13. Interpreting Information	✓
2. Observing		8. Predicting		14. Designing	
3. Comparing		9. Hypothesizing		15. Making/ constructing	
4. Measuring		10. Planning Investigations		16. Evaluating and improving products	
5. Sorting & Classifying		11. Doing Investigations		17. Communicating	
6. Identifying problems & issues		12. Recording Information	✓		

## TOPIC: The Solar System

### **B** POSSIBLE RESOURCES

For this lesson, you will need:

IDEAL RESOURCES	IMPROVISED RESOURCES
Resource 12: The Surface of the Moon	

### **C** CLASSROOM MANAGEMENT

1. Make sure that you are ready and prepared.
2. Write the following question onto the chalkboard before the lesson starts:

Which planet takes the longest time to orbit the Sun? Give a reason for your answer.

3. Learners should enter the classroom and answer the question in their workbooks.
4. Discuss the answer with the learners.
5. Write the model answer onto the chalkboard.

*Neptune takes the longest time to orbit the Sun. It is the furthest planet from the Sun and so has the longest path to travel around the Sun.*

## TOPIC: The Solar System

### D

### ACCESSING INFORMATION

1. Write the following onto the chalkboard (always try to do this before the lesson starts):

#### MOONS

Moons, like planets, do not give off their own heat or light.

They get their heat and light from the Sun.

Earth has 1 moon.

Jupiter has 69 moons.

Moons orbit their own planets.

PLANET	MOONS
Mercury	0
Venus	0
Earth	1
Mars	2
Jupiter	69
Saturn	62
Uranus	27
Neptune	13

Table showing the number of moons per planet

#### THE EARTH'S MOON

1. The Moon has no air or water.
2. The Sun's light shines onto the surface of the Moon.
3. There are many craters on the Moon which give it light and dark areas.
4. Some of the craters are very big.
5. The changing patterns of the sunlight on the Moon are called the Phases of the Moon.
6. This sunlight pattern gets repeated every 29  $\frac{1}{4}$  days.
7. This is how long it takes the Moon to orbit the Earth.
8. There is no wind or rain on the Moon.

## TOPIC: The Solar System

9. Explain the following to the learners:
  - a. Look at the picture of the Moon when it is full. Look at the light and dark areas. Show learners Resource 12: The Moon's Surface.
  - b. The surface of the Moon is rough and uneven. There are many valleys and mountains.
  - c. The tall mountains are the light areas you see and the valleys and craters are the dark areas.
  - d. Unlike the Earth, the Moon has no atmosphere (gas surrounding the planet).
  - e. The first man walked on the Moon on July 20th, 1969.
  - f. This man was an American named Neil Armstrong.
  - g. He said some very famous words as he stepped on the Moon: 'That's one small step for a man, one giant leap for mankind'.
  - h. His footsteps are still on the Moon.
3. Give learners some time to copy the above information into their workbooks.

### **Checkpoint 1**

Ask the learners the following questions to check their understanding at this point:

- a. Where does the Moon get its heat and light from?
- b. How many days does it take for the Moon to orbit the Earth?

Answers to the checkpoint questions are as follows:

- a. The Sun
- b. 29  $\frac{1}{4}$  days

## **E** CONCEPTUAL DEVELOPMENT

1. Read the following to learners:

One of the most historic events in the world's history, was when three American men landed on the Moon. On 20th July, 1969, Neill Armstrong became the first man to set foot on the Moon. He said some very famous words as he did this. He said: 'That's one small step for man, one giant leap for mankind'. The two men that walked on the moon wore spacesuits that controlled the temperature of their bodies and supplied them with oxygen. Neill Armstrong's footprints are still on the Moon. They spent 2  $\frac{1}{2}$  hours on the Moon. They collected soil and rocks from the Moon's surface.
2. Ask learners the following:
  - Why are Neill Armstrong's footprints still on the moon? (*There is no rain or wind on the Moon, so there is nothing to take his footprints away.*)
  - Why, do you think, did these two men collect soil and rocks from the Moon's surface? (*So that scientists could study these back on Earth.*)

## TOPIC: The Solar System

### **Checkpoint 2**

Ask the learners the following questions to check their understanding at this point:

- a. Which of the following elements does the Moon have: air, water, wind, rain?
- b. Who was the first man to walk on the Moon?

Answers to the checkpoint questions are as follows:

- a. None of them
- b. Neil Armstrong

3. Ask the learners if they have any questions and provide answers and explanations.

## **F** REFERENCE POINTS FOR FURTHER DEVELOPMENT

If you need additional information or activities on this topic, you can find these in your textbook on the following pages:

NAME OF TEXTBOOK	TOPIC	PAGE NUMBER
Study & Master	The Solar System	146-148
Viva	The Solar System	164-166
Platinum	The Solar System	176-178
Solutions for All	The Solar System	267-271
Day-by-Day	The Solar System	156-159
Oxford	The Solar System	120-121
Spot On	The Solar System	82-83
Top Class	The Solar System	126
Sasol Inzalo	The Solar System	121-129

## **G** ADDITIONAL ACTIVITIES/ READING

In addition, further reading, listening or viewing activities related to this sub-topic are available through the following web links:

1. <http://www.planetsforkids.org/moon-moon.html> [The Moon]
2. <https://www.youtube.com/watch?v=RMINS7MmT4> (1 ½ mins) [The Landing on the Moon]

# TOPIC OVERVIEW:

## Earth and Beyond

### Term 4, Weeks 3B – 4A

#### A. TOPIC OVERVIEW

##### Term 4, Weeks 3b – 4a

- This topic runs for 1 week.
- It is presented over 3 lessons.
- This topic counts for 12% in the end of year final exam.
- This topic's position in the term is as follows:

LESSON	WEEK 1			WEEK 2			WEEK 3			WEEK 4			WEEK 5		
	A	B	C	A	B	C	A	B	C	A	B	C	A	B	C
LESSON	WEEK 6			WEEK 7			WEEK 8			WEEK 9			WEEK 10		
	A	B	C	A	B	C	A	B	C	A	B	C	A	B	C

#### B. SEQUENTIAL TABLE

GRADE 5	GRADE 6	GRADE 6
<b>LOOKING BACK</b>	<b>CURRENT</b>	<b>LOOKING FORWARD</b>
<ul style="list-style-type: none"> <li>• The Earth moving around the Sun</li> <li>• The Earth moves in an orbit</li> <li>• The Earth spins on its own axis</li> </ul>	<ul style="list-style-type: none"> <li>• Movement of the Earth and planets: Revolution and Rotation</li> </ul>	<ul style="list-style-type: none"> <li>• The Earth's position in the Solar system</li> </ul>

#### C. SCIENTIFIC AND TECHNOLOGICAL VOCABULARY

Ensure that you teach the following vocabulary at the appropriate place in the topic:

	TERM	EXPLANATION
1.	axis	An imaginary line running through a planet
2.	tilted	Tipped at an angle
3.	anti-clockwise	The opposite direction to which the hands of a clock turn; if you are standing still and you start turning to the left you are turning in a anti-clockwise direction
4.	circular	A route or pathway shaped like a circle
5.	elliptical	A route or pathway shaped like a oval



## D. UNDERSTANDING THE USES / VALUE OF SCIENCE

Learners will understand how the Earth rotates, giving us night and day, and also how the Earth orbits around the Sun to give us our seasons.

## E. PERSONAL REFLECTION

Reflect on your teaching at the end of each topic:

Date completed:	
Lesson successes:	
Lesson challenges:	
Notes for future improvement:	

## TOPIC: Movements of the Earth and Planets

# 3 B

### Term 4, Week 3, Lesson B

### Lesson Title: Rotation of the Earth

### Time for lesson: 1 hour

## A

### POLICY AND OUTCOMES

<b>Sub-Topic</b>	Rotation
<b>CAPS Page Number</b>	62

#### Lesson Objectives

By the end of the lesson, learners will be able to:

- understand what rotation of a planet means
- understand the concept of an axis of a planet
- demonstrate how the Earth rotates on its own axis

Specific Aims	1. DOING SCIENCE & TECHNOLOGY	
	2. KNOWING THE SUBJECT CONTENT & MAKING CONNECTIONS	✓
	3. UNDERSTANDING THE USES OF SCIENCES & INDIGENOUS KNOWLEDGE	

### SCIENCE PROCESS SKILLS

1. Accessing & recalling Information	✓	7. Raising Questions		13. Interpreting Information	✓
2. Observing	✓	8. Predicting		14. Designing	
3. Comparing		9. Hypothesizing		15. Making/ constructing	
4. Measuring		10. Planning Investigations		16. Evaluating and improving products	
5. Sorting & Classifying		11. Doing Investigations	✓	17. Communicating	✓
6. Identifying problems & issues		12. Recording Information	✓		

## TOPIC: Movements of the Earth and Planets

### B POSSIBLE RESOURCES

For this lesson, you will need:

IDEAL RESOURCES	IMPROVISED RESOURCES
Resource 18: The Rotation of the Earth	An orange (or similar fruit or vegetable) with a pencil or stick stuck through the centre
Resource 19: Demonstration of day and night	

### C CLASSROOM MANAGEMENT

1. Make sure that you are ready and prepared.
2. Write the following question onto the chalkboard before the lesson starts:

Name one way in which rocks are broken in nature.

3. Learners should enter the classroom and answer the question in their workbooks.
4. Discuss the answer with the learners.
5. Write the model answer onto the chalkboard.

*The Moon does not have any wind or rain to wash or blow the footprints away.*

### D ACCESSING INFORMATION

1. Write the following table onto the chalkboard (always try to do this before the lesson starts):

#### THE EARTH'S ROTATION

- a. To rotate on an axis means to turn about a centre point.
  - b. We call this centre point an axis.
  - c. An axis is an imaginary line that runs through a planet.
  - d. Each planet rotates on its own axis.
  - e. It rotates in an anti-clockwise direction.
  - f. The Earth's axis runs from the North Pole to the South Pole.
  - g. The Earth's axis is tilted.
  - h. The Earth takes 24 hours to rotate fully
2. Explain this to learners as follows:
    - a. Rotate means to turn or spin.
    - b. An **axis** is an imaginary line running through a planet, from top to bottom.
    - c. The Earth's axis runs from the North Pole to the South Pole.
    - d. The Earth/s it is tilted.
    - e. The Earth's axis is at an angle.
    - f. The Earth rotates around its axis. This takes 24 hours.

## TOPIC: Movements of the Earth and Planets

3. Give learners some time to copy the information on the chalkboard into their workbooks.

### **Checkpoint 1**

Ask the learners the following questions to check their understanding at this point:

- a. What does 'to rotate' mean?
- b. Which two points on the Earth's surface does its axis run through?

Answers to the checkpoint questions are as follows:

- a. To turn or to spin
- b. North Pole and South Pole

## **E**

### **CONCEPTUAL DEVELOPMENT**

1. Ask learners to stand up. Get them to put up their left hand. Get them to turn on the spot by turning to the left. Tell them this direction of turning is called anti-clockwise (it is the opposite direction to how the hands on a clock turn).
2. Explain that the Earth turns around. This is called rotating. The Earth rotates in an anti-clockwise direction.
3. It seems as if the Sun is moving past us, but the Sun does not move. The Earth turns which makes it seem as if the Sun is moving.
4. Draw the image below onto the chalkboard and tell the learners to think of the Earth as an orange with a pencil through it. The pencil is the Earth's axis. In this image, the learners can see that the axis is tilted, which means the Earth is at an angle. It is not upright.

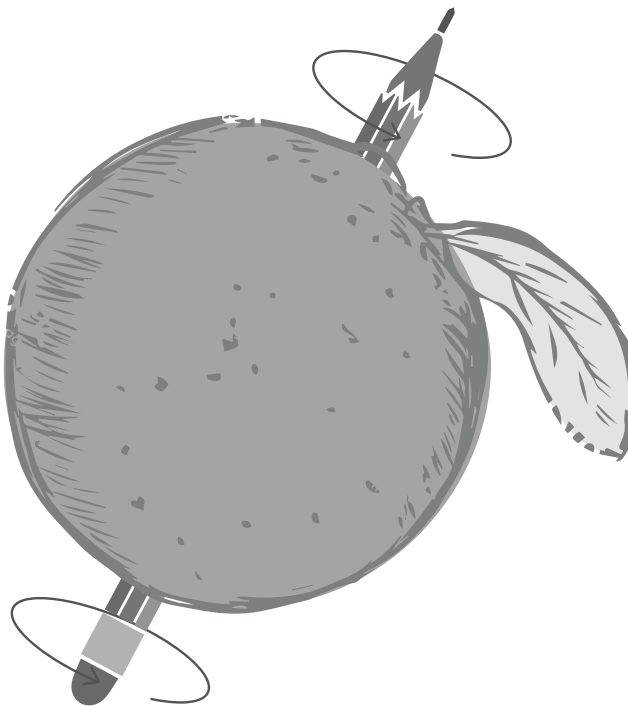

**The Earth Rotates on its Own Axis**

## TOPIC: Movements of the Earth and Planets

5. If you twist the pencil, the orange turns around. This is like the Earth rotating. The pencil represents the axis of the orange.
6. Show the learners Resource 18: 'The Rotation of the Earth'. Explain that the Earth's axis runs from the North Pole to the South Pole. Show learners that the axis is tilted.
7. Show learners the arrows on the drawing. This shows that the Earth rotates in an anti-clockwise direction.

### **Checkpoint 2**

Ask the learners the following questions to check their understanding at this point:

- a. What is a planet's axis?
- b. In what direction does the Earth rotate?

Answers to the checkpoint questions are as follows:

- a. An axis is an imaginary line running through a planet, from the North Pole to the South Pole.
- b. It rotates in an anti-clockwise direction.

8. Ask the learners if they have any questions and provide answers and explanations.

## **F** REFERENCE POINTS FOR FURTHER DEVELOPMENT

If you need additional information or activities on this topic, you can find these in your textbook on the following pages:

NAME OF TEXTBOOK	TOPIC	PAGE NUMBER
Study & Master	Movements of the Earth and planets	149-150
Viva	Movements of the Earth and planets	169-170
Platinum	Movements of the Earth and planets	184-185
Solutions for All	Movements of the Earth and planets	276-277
Day-by-Day	Movements of the Earth and planets	162-164
Oxford	Movements of the Earth and planets	122-123
Spot On	Movements of the Earth and planets	84
Top Class	Movements of the Earth and planets	129-130
Sasol Inzalo BkB	Movements of the Earth and planets	137-138

## **G** ADDITIONAL ACTIVITIES / READING

In addition, further reading, listening or viewing activities related to this sub-topic are available through the following web links:

1. <https://goo.gl/vmBxBM> (9 mins) [Rotation and Revolution of Earth]

## TOPIC: Movements of the Earth and Planets

# 3 C

### Term 4, Week 3, Lesson C

### Lesson Title: Rotation of the Earth

### Time for lesson: 1½ hours

## A

### POLICY AND OUTCOMES

<b>Sub-Topic</b>	Day and Night
<b>CAPS Page Number</b>	62

#### Lesson Objectives

By the end of the lesson, learners will be able to:

- demonstrate how day and night happen
- explain how the rotation of the Earth causes day and night

Specific Aims	1. DOING SCIENCE & TECHNOLOGY	✓
	2. KNOWING THE SUBJECT CONTENT & MAKING CONNECTIONS	✓
	3. UNDERSTANDING THE USES OF SCIENCES & INDIGENOUS KNOWLEDGE	

### SCIENCE PROCESS SKILLS

1. Accessing & recalling Information	✓	7. Raising Questions		13. Interpreting Information	✓
2. Observing	✓	8. Predicting		14. Designing	✓
3. Comparing		9. Hypothesizing		15. Making/ constructing	
4. Measuring		10. Planning Investigations		16. Evaluating and improving products	
5. Sorting & Classifying		11. Doing Investigations	✓	17. Communicating	✓
6. Identifying problems & issues		12. Recording Information	✓		

## TOPIC: Movements of the Earth and Planets

### B POSSIBLE RESOURCES

For this lesson, you will need:

IDEAL RESOURCES	IMPROVISED RESOURCES
Resource 19: Demonstration of night and day	
A torch or other source of light	

### C CLASSROOM MANAGEMENT

1. Make sure that you are ready and prepared.
2. Write the following question onto the chalkboard before the lesson starts:

Which planet takes the longer time to revolve around the Sun, the Earth or Jupiter? Explain your answer.

3. Learners should enter the classroom and answer the question in their workbooks.
4. Discuss the answer with the learners.
5. Write the model answer onto the chalkboard.

*Jupiter takes longer to revolve around the Sun because it is further away from the Sun so its orbit will be longer.*

### D ACCESSING INFORMATION

1. Write the following table onto the chalkboard (always try to do this before the lesson starts):

#### DAY AND NIGHT

1. The Sun is at the centre of the Solar System.
  2. The Sun gives off light.
  3. The Earth rotates on its own axis and around the Sun.
  4. The Sun's light shines on the Earth.
  5. The side of the Earth facing the Sun will be in daytime.
  6. The other side of the Earth will be in darkness.
  7. It takes 24 hours for the Earth to rotate once on its own axis.
2. Explain this to learners as follows:
    - a. The Sun is at the centre of the Solar System. It gives off light as it is a star.
    - b. The Earth rotates on its own axis.
    - c. As it rotates, the part of the Earth facing the Sun will experience daytime. The other half of the Earth will experience night time.
  3. Give learners some time to copy the above information from the chalkboard into their workbooks.

## TOPIC: Movement of the Earth and Planets

### **Checkpoint 1**

Ask the learners the following questions to check their understanding at this point:

- a. Which part of the Earth is in the light?
- b. How long does it take for the Earth to rotate once fully on its own axis?

Answers to the checkpoint questions are as follows:

- a. The part facing the Sun
- b. 24 hours

## **E**

### **CONCEPTUAL DEVELOPMENT**

1. To do this activity, you will need the following:
  - A balloon (have a spare balloon available)
  - A permanent marker or koki pen
  - ½m string or wool
  - A torch (you can use your cellphone torch or a mirror to reflect sunlight)
  - A map of Africa
2. Ensure you have these materials prepared before the lesson starts.
3. Tell the learners that they are going to be doing an investigation.
4. Write the following onto the chalkboard (always try to do this before the lesson starts):

### **PRACTICAL TASK**

1. This practical task will be done as a class.
2. We will be exploring how we get day and night.
3. Each person in the class must participate in the investigation and complete the answers to the written activities in their workbooks.
4. We will need the following materials and equipment to do the investigation:
  - A balloon (have a spare balloon available)
  - A permanent marker or koki pen
  - ½m string or wool
  - A torch (you can use your cellphone torch or a mirror to reflect sunlight)
  - A map of Africa
5. You will need to listen and observe.



## TOPIC: Movement of the Earth and Planets

5. Read through the practical task with the learners.
6. Remind the learners that the Earth rotates on its axis.
7. Tell the learners that today they are going to be investigating the difference between day and night.

### **Practical set-up (Do this before the lesson)**

1. Blow up the balloon and knot it closed.
  2. Tie the piece of string to the knot.
  3. Trace the Map of Africa onto the balloon using the permanent marker.
8. You will need to use 2 learners to help you with the practical demonstration:
    - 1 to hold the string attached to the balloon
    - 1 to hold the torch
    - They must stand about 2m apart from each other.
  9. Ask the learners to identify what the balloon represents.  
(The balloon represents Earth).
  10. Ask the learners to identify what the torch represents.  
(The torch represents the sun).
  11. Ask the learner holding the balloon to spin the balloon slowly anticlockwise.
  12. Ask the class why we spin the balloon.  
(We spin the balloon to represent Earth's rotation).
  13. Make the room as dark as possible – or go to a dark room.
  14. Ask the learner to hold the balloon still and to face the map of Africa towards the person holding the torch.
  15. Ask the learner holding the torch to shine the light onto the map.
  16. Ask the learner to spin the balloon again slowly and ask the class to observe what happens to the map.
  17. Explain that when the light shines on Africa it is daytime and that they must note that when the map turns away from the map it becomes night.
  18. Ask them if they have any questions.
  19. Demonstrate this a few times and ask them to identify where Cape Town, Pretoria and Durban are on the map which is on the balloon. You can point this out to them.
  20. Ask them to take note of which city gets sunlight first.
  21. Write the following onto the chalkboard (always try to do this before the lesson starts):

## TOPIC: Movements of the Earth and Planets

### TASK: (15 marks)

1. In the practical what does the balloon represent? (1)
2. In the practical what does the torch represent? (1)
3. Explain what is meant by Earth's rotation. (2)
4. How many hours pass for the Earth to turn around once? (1)
5. Which city will have daytime first, Cape Town or Durban? (1)
6. Which side of the Earth would be in the dark? (1)
7. Copy the diagram into your books and fill in the following labels:  
(Remember to draw in pencil and label in pen). Give the diagram a heading.
  - Sun
  - Light rays
  - Earth
  - Day
  - Night

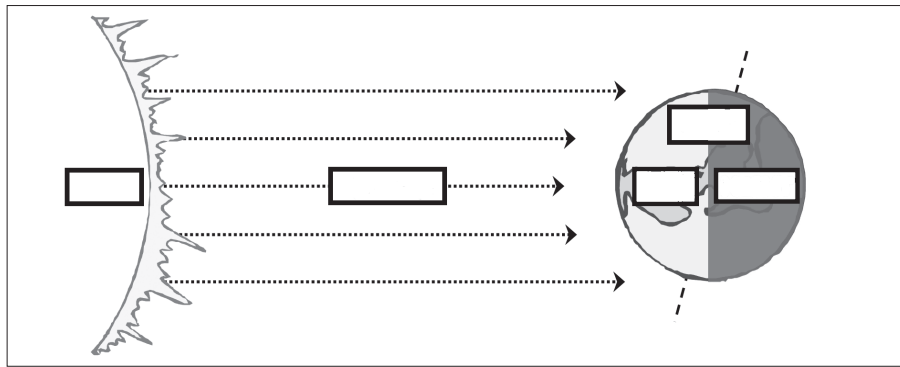

22. Read through the questions with the learners.
23. Demonstrate the balloon moving with the torch shining again.
24. Ask the learners to copy the questions into their books.
25. Tell the learners they have 10 minutes to answer these questions in their workbooks.
26. Supervise the learners whilst they complete the task and answer any questions they may have.
27. Collect books for assessment.

## TOPIC: Movements of the Earth and Planets

### F REFERENCE POINTS FOR FURTHER DEVELOPMENT

If you need additional information or activities on this topic, you can find these in your textbook on the following pages:

NAME OF TEXTBOOK	TOPIC	PAGE NUMBER
Study & Master	Movements of the Earth and planets	149-150
Viva	Movements of the Earth and planets	171
Platinum	Movements of the Earth and planets	185-186
Solutions for All	Movements of the Earth and planets	276-279
Day-by-Day	Movements of the Earth and planets	165-166
Oxford	Movements of the Earth and planets	123
Spot On	Movements of the Earth and planets	185
Top Class	Movements of the Earth and planets	-
Sasol Inzalo BkB	Movements of the Earth and planets	134

### G ADDITIONAL ACTIVITIES / READING

In addition, further reading, listening or viewing activities related to this sub-topic are available through the following web links:

1. <https://goo.gl/iyaq5e> (1 min) [Earth rotation - Day Night cycle]

## TOPIC: The Solar System

# 4 A

### Term 4, Week 4, Lesson A

### Lesson Title: The Sun, Planets and Asteroids

### Time for lesson: 1 hour

## A

### POLICY AND OUTCOMES

<b>Sub-Topic</b>	The Gas Planets
<b>CAPS Page Number</b>	61

#### Lesson Objectives

By the end of the lesson, learners will be able to:

- name the four gas planets
- describe their features

Specific Aims	1. DOING SCIENCE & TECHNOLOGY	
	2. KNOWING THE SUBJECT CONTENT & MAKING CONNECTIONS	✓
	3. UNDERSTANDING THE USES OF SCIENCES & INDIGENOUS KNOWLEDGE	

### SCIENCE PROCESS SKILLS

1. Accessing & recalling Information	✓	7. Raising Questions		13. Interpreting Information	✓
2. Observing		8. Predicting		14. Designing	
3. Comparing		9. Hypothesizing		15. Making/ constructing	
4. Measuring		10. Planning Investigations		16. Evaluating and improving products	
5. Sorting & Classifying		11. Doing Investigations		17. Communicating	
6. Identifying problems & issues	✓	12. Recording Information			

## TOPIC: The Solar System

### B POSSIBLE RESOURCES

For this lesson, you will need:

IDEAL RESOURCES	IMPROVISED RESOURCES
Poster: The Solar System	
Resource 2: Diagram of the larger outer planets and the smaller inner planets	
Resource 9: The Four Gas Planets	

### C CLASSROOM MANAGEMENT

1. Make sure that you are ready and prepared.
2. Write the following question onto the chalkboard before the lesson starts:

Name the four inner rocky planets.

3. Learners should enter the classroom and answer the question in their workbooks.
4. Discuss the answer with the learners.
5. Write the model answer onto the chalkboard.

*Mercury, Venus, Earth, Mars*

### D ACCESSING INFORMATION

1. Write the following onto the chalkboard (always try to do this before the lesson starts).  
Learners will copy this information in two stages:

#### THE FOUR GAS PLANETS

##### JUPITER

1. Jupiter is the largest planet.
2. It has strong winds.
3. These winds blow the gases and this makes the planet look streaky.
4. 69 moons have been discovered but there may be more.
5. It is a cold planet with an average temperature of  $-110^{\circ}\text{C}$ .

##### SATURN

1. Saturn has seven rings around it.
2. It has 62 moons.

## TOPIC: The Solar System

### URANUS

1. Uranus is a frozen gas planet.
2. Its average temperature is  $-195^{\circ}\text{C}$ .
3. It looks as if it is leaning over - it has a tilted axis.
4. It has nine dark rings and two light rings.
5. There are 27 moons.
6. It orbits the Earth every 84 Earth years.

### NEPTUNE

1. Neptune is also a frozen gas planet.
2. It is a very cold planet with an average temperature of  $-214^{\circ}\text{C}$ .
3. It also has very fast winds.
4. It has a blue-green colour.

2. Show learners Resource 2: 'The larger outer planets compared to the smaller inner planets'.  
g the sun will experience daytime. The other half of the Earth will experience night time.
3. Explain about Jupiter and Saturn as follows:
  - a. Show the learners planet Jupiter on the diagram in Resource 2 (It is the fifth planet from the Sun).
  - b. Jupiter is the largest planet.
  - c. Jupiter can fit 1 400 (one thousand four hundred) Earths inside (these Earths would have to be melted).
  - d. Jupiter has very strong winds that blow the gases. This makes the planet look streaky (get learners to look at Resource 10: Jupiter).
  - e. 69 moons have been discovered orbiting Jupiter but there may still be more.
  - f. Show learners Saturn on the diagram in Resource 2 (It is the sixth planet, with rings).
  - g. Saturn has seven rings made up of gas and ice (Show learners Resource 11: Saturn).
  - h. Like Jupiter, Saturn has many moons.
  - i. Saturn has 62 moons.
4. Give learners some time to copy this information about Jupiter and Saturn into their workbooks.

## TOPIC: The Solar System

5. Explain Uranus and Neptune to the learners as follows:
  - a. Show learners Uranus on the Diagram from Resource 2 (Uranus is the seventh planet from the Sun).
  - b. Uranus and Neptune are frozen gas planets.
  - c. They are both very cold.
  - d. Uranus has a tilted axis – it looks as if it is leaning over.
  - e. It has 11 rings surrounding it.
  - f. 27 moons orbit Uranus.
  - g. Neptune is the furthest planet from the Sun.
  - h. It takes a long time to orbit the Sun.
  - i. Neptune has very fast winds.
  - j. It has 14 moons and 6 dark rings. Get learners to draw the following sketch in their workbooks. The drawing must have labels and a title.
6. Give learners some time to copy this information about Uranus and Neptune into their workbooks.

### **Checkpoint 1**

Ask the learners the following questions to check their understanding at this point:

- a. Which is the largest planet?
- b. Which two planets are made from frozen gas?

Answers to the checkpoint questions are as follows:

- a. Jupiter
- b. Uranus and Neptune

## **E** CONCEPTUAL DEVELOPMENT

1. Show learners Resource 9: "The Four Gas Planets". Ask them to look at the image carefully.
2. Ask learners the following (answers are in italics):
  - a. What are these four planets made of? (*They are made of gas*)
  - b. Which is the coldest planet? (*Neptune*)
  - c. Why is Neptune the coldest planet? (*It is the furthest from the Sun*)
  - d. Which planet has the most moons? (*Jupiter*)
  - e. What are Neptune and Uranus made up of? (*Frozen gas*)
  - f. Which planet is tilted on its axis? (*Uranus*)
  - g. Which is the largest planet? (*Jupiter*)

## TOPIC: The Solar System

3. Give the following activity to the class. This is a cloze activity. Write the sentences and the words on the chalkboard. Learners must copy the paragraph and choose the correct word from the given list to fill in the spaces. Learners must underline the words that they have filled in.

Saturn is the sixth planet from the Sun but it is the second \_\_\_\_\_ planet.

\_\_\_\_\_ is the furthest planet from the Sun.

Jupiter is the largest planet in our \_\_\_\_\_ .

Jupiter, Saturn, Uranus and Neptune are the \_\_\_\_\_ gas planets.

These four planets are made mostly of \_\_\_\_\_ .

All of these gas planets are surrounded by \_\_\_\_\_ .

### Words to choose from:

gas, largest, Solar System, Neptune, four, rings

Answer:

Saturn is the sixth planet from the Sun but it is the second largest planet.

Neptune is the furthest planet from the Sun.

Jupiter is the largest planet in our Solar System.

Jupiter, Saturn, Uranus and Neptune are the four gas planets.

These four planets are made mostly of gas.

All of these gas planets are surrounded by rings.

4. If time allows, do the following activity:

Tell the learners that you are going to play the following game. Ask learners to listen to the clues and then write down the planet being described from the clues. Answers are in italics after the clues. Read out all four sets of clues before giving any answers.

What Planet am I?

1. I am a gas planet.

I am also an outer planet.

I am made from frozen gas.

I am the planet furthest from the Sun.

I am the coldest planet.

*(Neptune)*

2. I am a gas planet.

I am an outer planet.

I have a tilted axis.

My average temperature is  $-195^{\circ}\text{C}$ .

I have 27 moons.

*(Uranus)*



## TOPIC: The Solar System

3. I am a gas planet.

I am an outer planet.

I am the largest planet in the Solar System.

Strong winds blow my gases which gives me a streaky appearance.

I have the most moons of all the planets.

*(Jupiter)*

4. I am a gas planet.

I am an outer planet.

I have 7 rings and 62 moons.

*(Saturn)*

### **Checkpoint 2**

Ask the learners the following questions to check their understanding at this point:

- a. Which is the largest planet?
- b. Which two planets are made from frozen gas?

Answers to the checkpoint questions are as follows:

- a. Jupiter
- b. Uranus and Neptune

5. Ask learners if they have any questions and provide answers and explanations.

## TOPIC: The Solar System

### F REFERENCE POINTS FOR FURTHER DEVELOPMENT

If you need additional information or activities on this topic, you can find these in your textbook on the following pages:

NAME OF TEXTBOOK	TOPIC	PAGE NUMBER
Study & Master	The Solar System	143-144
Viva	The Solar System	154-157
Platinum	The Solar System	173
Solutions for All	The Solar System	256-259
Day-by-Day	The Solar System	154-155
Oxford	The Solar System	118
Spot On	The Solar System	80-81
Top Class	The Solar System	125
Sasol Inzalo BkB	The Gas Planets	109; 114 - 118

### G ADDITIONAL ACTIVITIES / READING

In addition, further reading, listening or viewing activities related to this sub-topic are available through the following web links:

1. <https://goo.gl/h9bAcV> [Gas Giant Planets: Quiz]
2. <https://goo.gl/C7V1Xu> (6 ½ mins) [Outer Planets of the Solar System]

# TOPIC OVERVIEW:

## The movement of the Moon

### Term 4, Weeks 4B – 5A

#### A. TOPIC OVERVIEW

##### Term 4, Weeks 4b – 5a

- This topic runs for 1 week.
- It is presented over 3 lessons.
- This topic counts for 12% in the end of year final exam.
- This topic's position in the term is as follows:

LESSON	WEEK 1			WEEK 2			WEEK 3			WEEK 4			WEEK 5		
		A	B	C	A	B	C	A	B	C	A	B	C	A	B

LESSON	WEEK 6			WEEK 7			WEEK 8			WEEK 9			WEEK 10		
		A	B	C	A	B	C	A	B	C	A	B	C	A	B

#### B. SEQUENTIAL TABLE

GRADE 5	GRADE 6	GRADE 6
<b>LOOKING BACK</b>	<b>CURRENT</b>	<b>LOOKING FORWARD</b>
<ul style="list-style-type: none"> <li>• Describe features of the Moon</li> <li>• Recognise the phases of the Moon</li> </ul>	<ul style="list-style-type: none"> <li>• Explain the movements of the Moon</li> </ul>	<ul style="list-style-type: none"> <li>• Interpret information about the features of objects in Space</li> <li>• Explain gravity and the Moon's effect on tides</li> </ul>

#### C. SCIENTIFIC AND TECHNOLOGICAL VOCABULARY

Ensure that you teach the following vocabulary at the appropriate place in the topic:

	TERM	EXPLANATION
1.	composition	The parts of something that when put together make up a whole
2.	satellite	Something that orbits around a planet. This can be a man-made object or a celestial object
3.	natural	Something that is not man-made
4.	spherical	Describes an object shaped like a ball

## D. UNDERSTANDING THE USES / VALUE OF SCIENCE

Learners will understand how the Earth rotates, giving us night and day, and also how the Earth orbits around the Sun to give us our seasons.

## E. PERSONAL REFLECTION

Reflect on your teaching at the end of each topic:

Date completed:	
Lesson successes:	
Lesson challenges:	
Notes for future improvement:	

**4 B**

Term 4, Week 4, Lesson B

Lesson Title: Rotation of the Moon

Time for lesson: 1 hour

**A POLICY AND OUTCOMES**

<b>Sub-Topic</b>	The Rotation of the Moon
<b>CAPS Page Number</b>	63

**Lesson Objectives**

By the end of the lesson, learners will be able to:

- demonstrate the rotation of the moon using physical actions
- explain the length of a single rotation

Specific Aims	1. DOING SCIENCE & TECHNOLOGY	✓
	2. KNOWING THE SUBJECT CONTENT & MAKING CONNECTIONS	✓
	3. UNDERSTANDING THE USES OF SCIENCES & INDIGENOUS KNOWLEDGE	

**SCIENCE PROCESS SKILLS**

1. Accessing & recalling Information	✓	7. Raising Questions	✓	13. Interpreting Information	✓
2. Observing	✓	8. Predicting	✓	14. Designing	
3. Comparing		9. Hypothesizing		15. Making/ constructing	
4. Measuring		10. Planning Investigations		16. Evaluating and improving products	
5. Sorting & Classifying		11. Doing Investigations	✓	17. Communicating	✓
6. Identifying problems & issues		12. Recording Information	✓		

## TOPIC: The movement of the Moon

### B POSSIBLE RESOURCES

For this lesson, you will need:

IDEAL RESOURCES	IMPROVISED RESOURCES
a ball with an X drawn on one side	
Resource 22: Rotation of the Moon	

### C CLASSROOM MANAGEMENT

1. Make sure that you are ready and prepared.
2. Write the following question onto the chalkboard before the lesson starts:

How long does it take the Earth to revolve around the Sun?

3. Learners should enter the classroom and answer the question in their workbooks.
4. Discuss the answer with the learners.
5. Write the model answer onto the chalkboard.

*365  $\frac{1}{4}$  days*

### D ACCESSING INFORMATION

1. Write the following onto the chalkboard (always try to do this before the lesson starts).

#### MOVEMENTS OF THE MOON

##### ROTATION

1. The Moon spins (rotates) on its own axis.
  2. One rotation takes about 28 days.
  3. We only see one side of the Moon. We call this side the Near Side.
  4. The side we do not see is called the Far Side.
2. Explain this to the learners as follows:
    - a. You discovered how the Earth rotates in a previous lesson. The Moon also rotates.
    - b. To rotate means to spin or turn on its own axis.
    - c. The Moon takes nearly 28 days to make one full rotation.
    - d. We only see one side of the Moon – the Near Side.
    - e. The side we cannot see from Earth is called the Far Side.
  3. Give learners some time to copy the above information into their workbooks.

## TOPIC: The movement of the Moon

### **Checkpoint 1**

Ask the learners the following questions to check their understanding at this point:

- a. How long does it take for the moon to make one full rotation?
- b. What do we call the side of the moon that we can see from Earth?

Answers to the checkpoint questions are as follows:

- a. Nearly 28 days
- b. The Near Side

## **E**

### **CONCEPTUAL DEVELOPMENT**

1. Explain the following to the learners:
  - a. We only see one side of the Moon from Earth, the Near Side.
  - b. This is how we know it is rotating.
  - c. If the Moon did not rotate, we would see all sides of the Moon.
  - d. It takes nearly 28 days for the Moon to rotate once on its own axis.
2. Ask one of the learners to help you with the following demonstration. Ask all the other learners to stand on one side of the classroom. Get the learner who is helping you, to hold the ball up at head height. The 'X' that has been drawn on the ball must face the learner. The learner must hold the ball in this same position and then turn in an anti-clockwise direction on the same spot while holding the ball up. The learner must turn once.

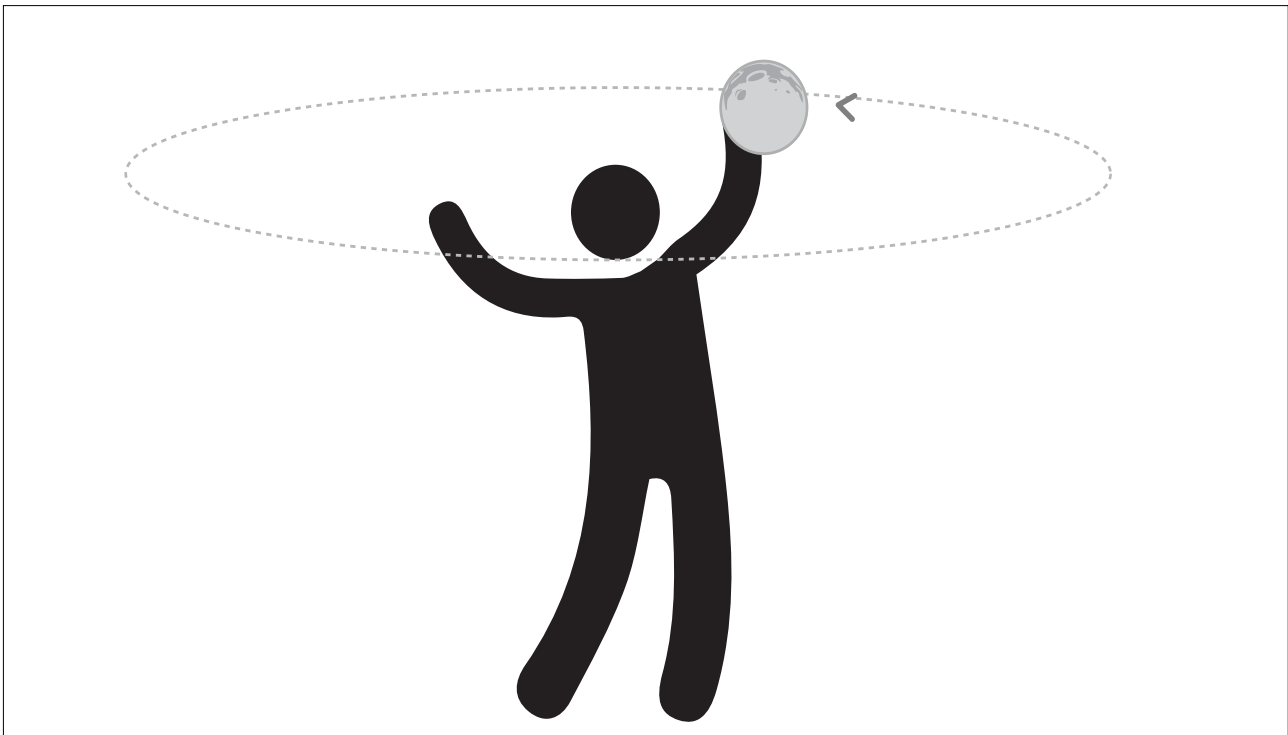

Demonstrating how the Moon revolves around the Earth

## TOPIC: The movement of the Moon

3. Ask the following questions about the demonstration. Answers are in italics.
  - a. Does the learner holding the ball and turning always see the same side of the ball? *Yes.*
  - b. Do the rest of you see the same side of the ball as the learner holding the ball is turning? *No. The 'X' will face the front of the classroom, then the side of the classroom, then the back of the classroom, then the other side of the classroom, and finally back to the front of the classroom.*
  - c. Do you think that the Moon rotates? *Yes, as the rest of the learners see different sides of the ball.*
  - d. What does the learner holding the ball represent? *The Earth.*
  - e. What does the ball represent? *The Moon.*
4. Ask the learner to demonstrate the Moon rotating one more time. Get the rest of the learners to observe what they see very carefully.
5. Ask learners to sit at their desks and take out their workbooks. Ask them to draw a diagram of the Moon orbiting the Earth and rotating once. The drawing must have:
  - a. A medium sized circle at the centre to represent Earth.
  - b. A circle around the Earth showing the orbit of the Moon.
  - c. A smaller circle on the orbit line on the right to represent the Moon.
  - d. Shade in half the Moon facing the Earth to show the Near Side of the Moon.
  - e. A smaller circle on the orbit line at the top to represent the Moon.
  - f. Shade in half the Moon facing the Earth to show the Near Side of the Moon.
  - g. Two more smaller circles on the orbit line on the left and at the bottom with the Near Side shaded in.
  - h. Labels for the 'Earth', 'The Moon's orbit' and 'The Moon'.
  - i. A title 'Rotation of the Moon'.



## TOPIC: The movement of the Moon

6. The learners' completed diagrams should look like this:

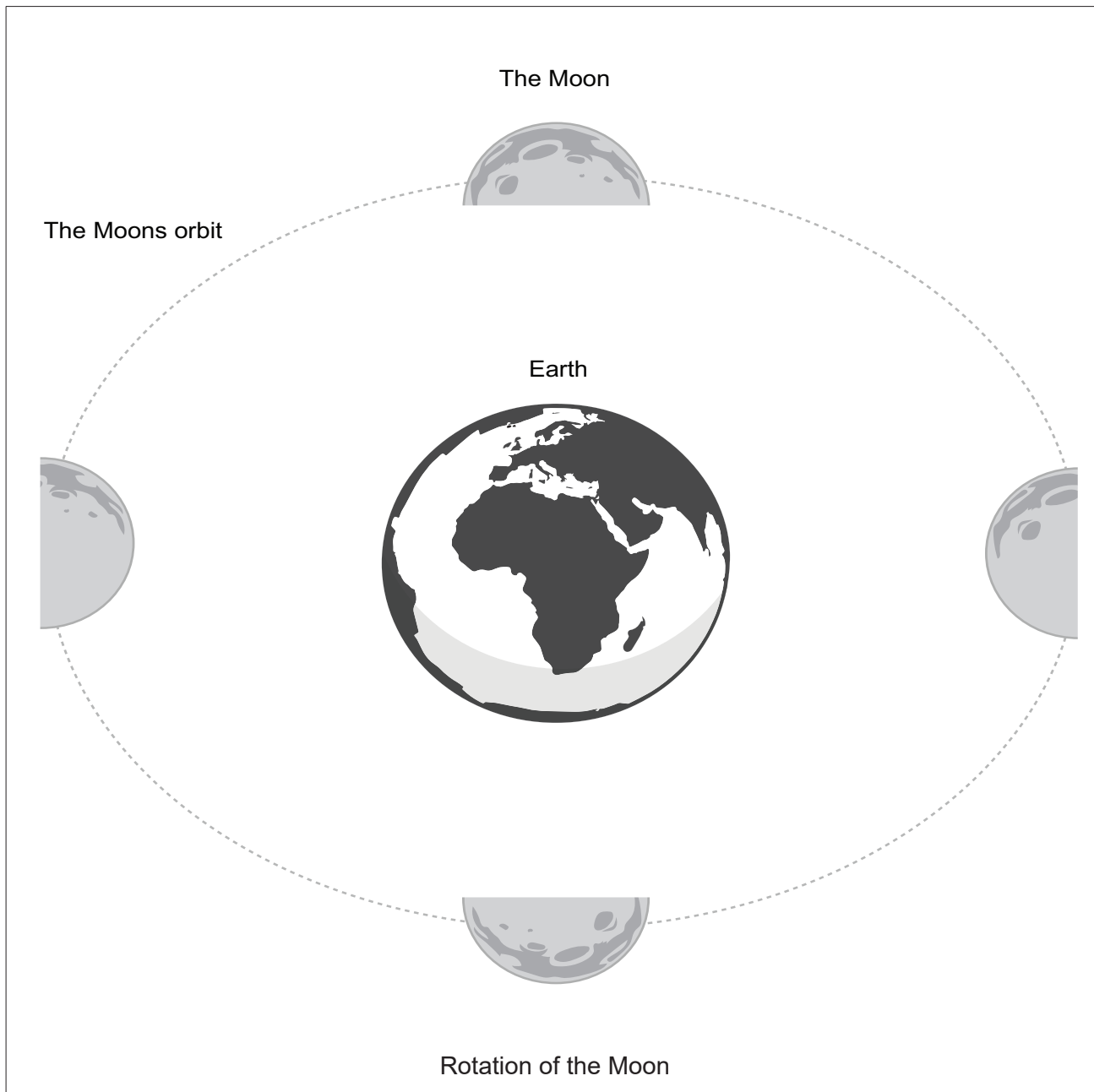

### **Checkpoint 2**

Ask the learners the following questions to check their understanding at this point:

- How many times does the Moon rotate on its own axis for one orbit around the Earth?
- How do we know that the Moon only rotates once for each orbit of the Earth?

Answers to the checkpoint questions are as follows:

- Once
- On Earth, we only see one side of the Moon

7. Ask the learners if they have any questions and provide answers and explanations.

## TOPIC: The movement of the Moon

### F REFERENCE POINTS FOR FURTHER DEVELOPMENT

If you need additional information or activities on this topic, you can find these in your textbook on the following pages:

NAME OF TEXTBOOK	TOPIC	PAGE NUMBER
Study & Master	The Movement of the Moon	156-157
Viva	The Movement of the Moon	175
Platinum	The Movement of the Moon	189
Solutions for All	The Movement of the Moon	287
Day-by-Day	The Movement of the Moon	173
Oxford	The Movement of the Moon	126-127
Spot On	The Movement of the Moon	86
Top Class	The Movement of the Moon	133
Sasol Inzalo BkB	The Movement of the Moon	148-149

### G ADDITIONAL ACTIVITIES / READING

In addition, further reading, listening or viewing activities related to this sub-topic are available through the following web links:

1. <https://goo.gl/rFZFaE> (2 ½ mins) [Rotation of the Moon]

**4 C**

**Term 4, Week 4, Lesson C**

**Lesson Title: Revolution of the Moon**

**Time for lesson: 1 hour**

**A POLICY AND OUTCOMES**

<b>Sub-Topic</b>	The Moon and how it revolves around the Earth
<b>CAPS Page Number</b>	63

**Lesson Objectives**

By the end of the lesson, learners will be able to:

- explain the revolution of the Moon around the Earth
- model the rotation and the revolution of the Moon around the Earth

Specific Aims	1. DOING SCIENCE & TECHNOLOGY	✓
	2. KNOWING THE SUBJECT CONTENT & MAKING CONNECTIONS	✓
	3. UNDERSTANDING THE USES OF SCIENCES & INDIGENOUS KNOWLEDGE	

**SCIENCE PROCESS SKILLS**

1. Accessing & recalling Information	✓	7. Raising Questions		13. Interpreting Information	✓
2. Observing	✓	8. Predicting	✓	14. Designing	
3. Comparing		9. Hypothesizing		15. Making/ constructing	
4. Measuring		10. Planning Investigations		16. Evaluating and improving products	
5. Sorting & Classifying		11. Doing Investigations	✓	17. Communicating	✓
6. Identifying problems & issues	✓	12. Recording Information	✓		

## TOPIC: The movement of the Moon

### B POSSIBLE RESOURCES

For this lesson, you will need:

IDEAL RESOURCES	IMPROVISED RESOURCES

### C CLASSROOM MANAGEMENT

1. Make sure that you are ready and prepared.
2. Write the following question onto the chalkboard before the lesson starts:

How long does it take the Moon to rotate once?

3. Learners should enter the classroom and answer the question in their workbooks.
4. Discuss the answer with the learners.
5. Write the model answer onto the chalkboard.

*Nearly 28 days*

### D ACCESSING INFORMATION

1. Write the following onto the chalkboard (always try to do this before the lesson starts).

#### REVOLUTION

1. The Moon revolves (orbits) around the Earth.
  2. One revolution takes about 28 days.
  3. It takes the same amount of time for the Moon to rotate on its own axis as it does to revolve around the Earth once.
  4. The force of gravity holds the Moon in its orbit with the Earth.
2. Explain this to the learners as follows:
    - a. The Moon takes the same amount of time to rotate once on its own axis as it does to revolve around the Earth.
    - b. This is why we see only one side of the Moon.
    - c. The force of gravity keeps the Moon in its orbit with the Earth instead of it going off in a straight line.
  3. Give learners some time to copy the information from the chalkboard into their workbooks.

## TOPIC: The movement of the Moon

### **Checkpoint 1**

Ask the learners the following questions to check their understanding at this point:

- a. How long does it take for the Moon to revolve around the Earth?
- b. How long does it take for the Moon to rotate on its axis?

Answers to the checkpoint questions are as follows:

- a. 28 days
- b. 28 days

## **E**

### **CONCEPTUAL DEVELOPMENT**

1. Explain the following to the learners:
  - a. The Moon takes 28 days to revolve around the Earth – this is approximately one month.
  - b. It takes the Moon the same time to rotate once on its own axis as it takes the Moon to revolve once around the Earth.
  - c. This is why we only see one side of the Moon from Earth.
  - d. The same side of the Moon always faces Earth.
2. Write the following on the chalkboard. Ask learners to take out their workbooks to complete the sentences.

#### THE MOVEMENT OF THE MOON

Choose from the following list of words to make the sentences below complete. Underline the word you have chosen.

28 days, 24 hours, Moon, Sun, Earth, same, rotation, revolution, gravity

- a. The \_\_\_\_ is at the centre of the Solar System.
- b. \_\_\_\_ means to spin or turn on an axis.
- c. \_\_\_\_ means to orbit around another object in Space.
- d. The \_\_\_\_ revolves around the Sun.
- e. The \_\_\_\_ revolves around the Earth.
- f. The Moon takes \_\_\_\_ to rotate on its axis.
- g. The Earth takes \_\_\_\_ to rotate on its axis.
- h. On Earth, we always see the \_\_\_\_ side of the Moon.
- i. The force of \_\_\_\_ keeps the Moon in its orbit with the Earth.

## TOPIC: The movement of the Moon

Answers are as follows:

- a. The Sun is at the centre of the Solar System.
- b. Rotation means to spin or turn on an axis.
- c. Revolution means to orbit around another object in Space.
- d. The Earth revolves around the Sun.
- e. The Moon revolves around the Earth.
- f. The Moon takes 28 days to rotate on its axis.
- g. The Earth takes 24 hours to rotate on its axis.
- h. On Earth, we always see the same side of the Moon.
- i. The force of gravity keeps the Moon in its orbit with the Earth.

3. Go outside with the learners. Remind learners of the activity done in the previous lesson (the one with the ball marked 'X'). Ask learners to get into pairs and to find a way to demonstrate the rotation and the revolution of the Moon. One learner must represent Earth and the other learner the Moon.

### **Checkpoint 2**

Ask the learners the following questions to check their understanding at this point:

- a. What force keeps the Moon in its orbit with the Earth?
- b. Why do we always see the same side of the Moon?

Answers to the checkpoint questions are as follows:

- a. Gravity
- b. The Moon takes the same amount of time to rotate on its own axis as it does to revolve around the Earth once.

4. Ask the learners if they have any questions and provide answers and explanations.

## TOPIC: The movement of the Moon

### F REFERENCE POINTS FOR FURTHER DEVELOPMENT

If you need additional information or activities on this topic, you can find these in your textbook on the following pages:

NAME OF TEXTBOOK	TOPIC	PAGE NUMBER
Study & Master	The Movement of the Moon	157
Viva	The Movement of the Moon	176-179
Platinum	The Movement of the Moon	190
Solutions for All	The Movement of the Moon	287-289
Day-by-Day	The Movement of the Moon	174
Oxford	The Movement of the Moon	128-129
Spot On	The Movement of the Moon	86
Top Class	The Movement of the Moon	133-134
Sasol Inzalo BkB	The Movement of the Moon	149-151

### G ADDITIONAL ACTIVITIES / READING

In addition, further reading, listening or viewing activities related to this sub-topic are available through the following web links:

1. <https://goo.gl/tFHWxR> (5 mins) [The Moon for Kids]

## TOPIC: The movement of the Moon

# 5 A

### Term 4, Week 5, Lesson A

### Lesson Title: Revolution of the Earth

### Time for lesson: 1½ hour

#### A POLICY AND OUTCOMES

<b>Sub-Topic</b>	Comparing the Earth, Moon and the Sun
<b>CAPS Page Number</b>	63

#### Lesson Objectives

By the end of the lesson, learners will be able to:

- compare the Sun, Earth and the Moon
- draw up a table of comparison

Specific Aims	1. DOING SCIENCE & TECHNOLOGY	
	2. KNOWING THE SUBJECT CONTENT & MAKING CONNECTIONS	✓
	3. UNDERSTANDING THE USES OF SCIENCES & INDIGENOUS KNOWLEDGE	

#### SCIENCE PROCESS SKILLS

1. Accessing & recalling Information	✓	7. Raising Questions		13. Interpreting Information	✓
2. Observing	✓	8. Predicting		14. Designing	
3. Comparing		9. Hypothesizing		15. Making/ constructing	
4. Measuring		10. Planning Investigations		16. Evaluating and improving products	
5. Sorting & Classifying		11. Doing Investigations	✓	17. Communicating	✓
6. Identifying problems & issues	✓	12. Recording Information	✓		



## TOPIC: The movement of the Moon

### B POSSIBLE RESOURCES

For this lesson, you will need:

#### IDEAL RESOURCES

A ball with an 'X' marked on it

#### IMPROVISED RESOURCES

### C CLASSROOM MANAGEMENT

1. Make sure that you are ready and prepared.
2. Write the following question onto the chalkboard before the lesson starts:

How long does it take for the Moon to revolve once around the Earth?

3. Learners should enter the classroom and answer the question in their workbooks.
4. Discuss the answer with the learners.
5. Write the model answer onto the chalkboard.

*28 days*

### D ACCESSING INFORMATION

1. Write the following onto the chalkboard (always try to do this before the lesson starts).

#### COMPARING THE SUN, EARTH AND MOON

1. The Sun, Earth and Moon are all objects in our Solar System.
  2. The Sun is a star at the centre of our Solar System.
  3. The Sun makes its own heat and light.
  4. The Sun is made of gas.
  5. The Sun is 1 300 000 times bigger than the Earth.
  6. The Earth is one of the eight planets orbiting the Sun.
  7. The Earth is made mostly of rock, soil and some water.
  8. The Moon is a natural satellite that orbits the Earth.
  9. Both the Moon and the Earth rotate on their own axis.
  10. The Moon orbits the Earth which orbits the Sun.
  11. The Moon is about  $\frac{1}{4}$  the size of the Earth.
  12. All three of these objects are spherical.
2. Explain this to the learners as follows:
    - a. The Sun is a very big star made mostly of gas that gives us the heat and light we need to survive.
    - b. The Earth, a planet, is made mostly of rocks, soil and water.
    - c. The Moon is a natural satellite which orbits the Earth. straight line.

## TOPIC: The movement of the Moon

### Checkpoint 1

Ask the learners the following questions to check their understanding at this point:

- a. Which is the smallest object – the Sun, the Earth or the Moon?
- b. The Earth orbits the Moon. True or False?

Answers to the checkpoint questions are as follows:

- a. The Moon
- b. False

## E

### CONCEPTUAL DEVELOPMENT

1. Draw the following table onto the chalkboard:

<b>COMPARING THE SUN, THE EARTH AND THE MOON</b>				
<b>Property</b>		<b>Sun</b>	<b>Earth</b>	<b>Moon</b>
Shape	Spherical	✓	✓	✓
Composition	Mostly rock, soil and water			
	Gas			
	Rock			
Size	The biggest object in the Solar System			
	The smallest object out of the three			
	Size in-between the other two objects			
Movement	Rotates on own axis, orbits a planet			
	Rotates on own axis, orbits a star			
	Does not move			
Can produce light? Yes or no.	Yes			
	No			

2. Explain this task to the learners as follows:
  - a. Copy the table into your workbook.
  - b. From the information written on the chalkboard and from what is written in your workbooks, put a tick in the correct column for each property.
3. Give learners some time to complete this task in their workbooks.
4. Draw the following diagram on the chalkboard.

## TOPIC: The movement of the Moon

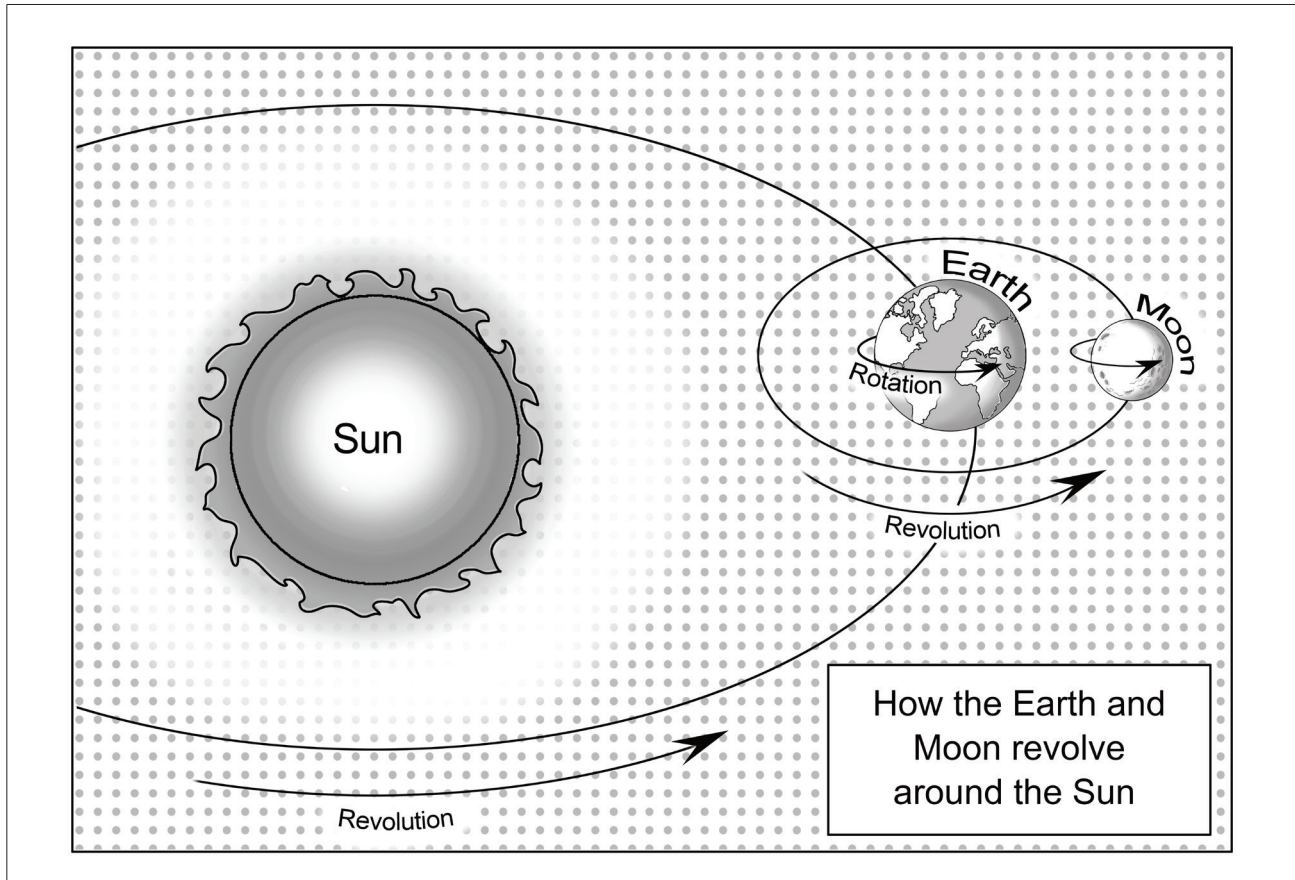

5. Explain the following to the learners:
  - a. Point to the arrows that show how the Moon rotates on its own axis as it revolves around the Earth.
  - b. Point to the arrows that show how the Earth rotates on its own axis as it revolves around the Sun.
  - c. The Sun is at the centre.
6. Ask learners to copy this diagram neatly into their workbooks.
7. Go outside with the learners. Ask for two learners to help demonstrate the Sun, Earth and Moon System by doing the following (use the diagram below to help you plan the activity):
  - a. The learner representing the Sun must stand in the middle of an open area.
  - b. Ask the learner representing the Earth to stand two metres away from the Sun.
  - c. This learner must hold the ball at shoulder height with the 'X' mark facing the learner.
  - d. The learner must start rotating by spinning left slowly.
  - e. At the same time as rotating, this learner must start to orbit the Sun.

## TOPIC: The movement of the Moon

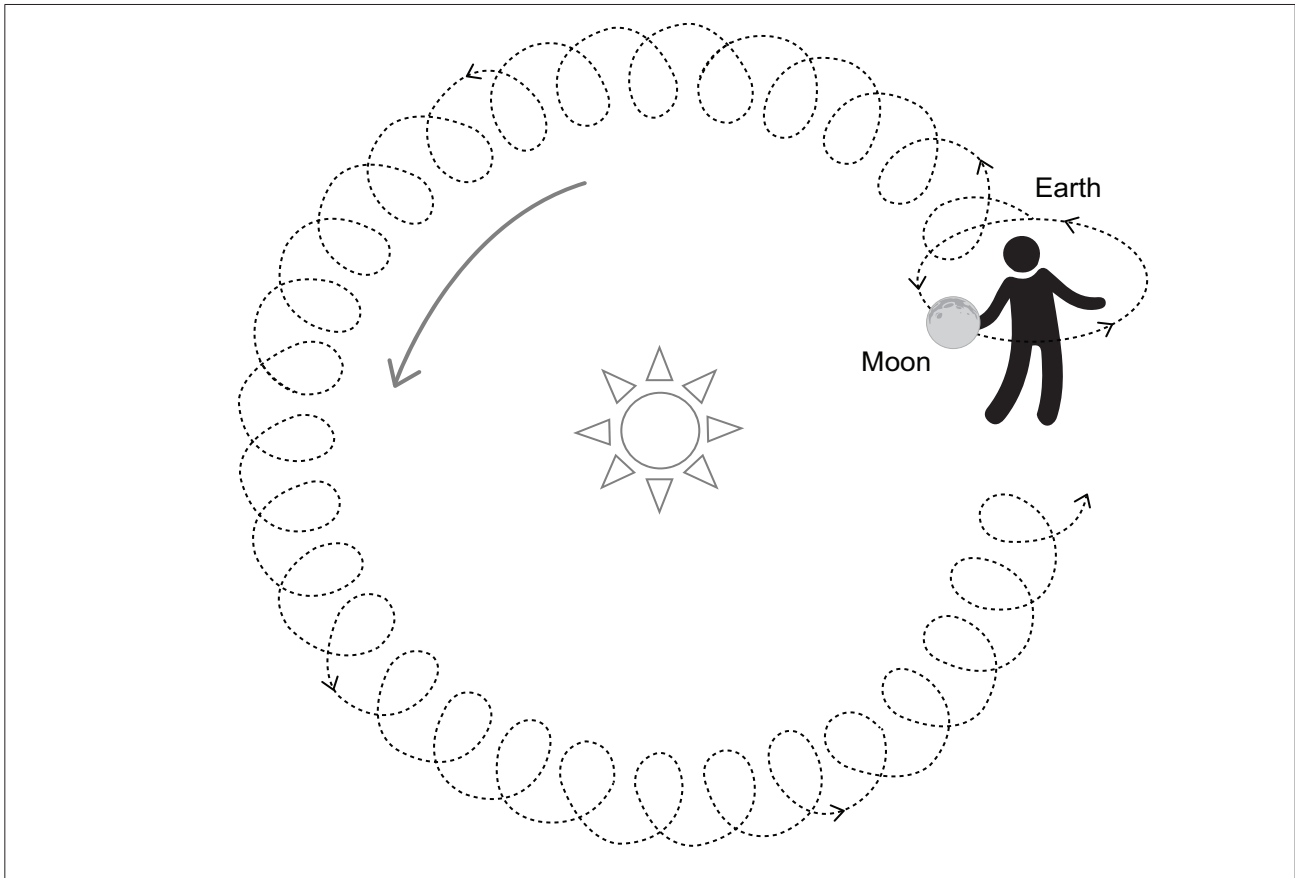

### **Checkpoint 2**

Ask the learners the following questions to check their understanding at this point:

- a. Which is the biggest object in the Solar system?
- b. Which object in the Solar System produces light and heat?

Answers to the checkpoint questions are as follows:

- a. The Sun
- b. The Sun

8. Ask the learners if they have any questions and provide answers and explanations.

## TOPIC: The movement of the Moon

### F REFERENCE POINTS FOR FURTHER DEVELOPMENT

If you need additional information or activities on this topic, you can find these in your textbook on the following pages:

NAME OF TEXTBOOK	TOPIC	PAGE NUMBER
Study & Master	The Movement of the Moon	159
Viva	The Movement of the Moon	179
Platinum	The Movement of the Moon	192-194
Solutions for All	The Movement of the Moon	292-295
Day-by-Day	The Movement of the Moon	175-177
Oxford	The Movement of the Moon	129
Spot On	The Movement of the Moon	87
Top Class	The Movement of the Moon	135
Sasol Inzalo	The Movement of the Moon	150-153

### G ADDITIONAL ACTIVITIES / READING

In addition, further reading, listening or viewing activities related to this sub-topic are available through the following web links:

1. <https://goo.gl/bEniV> (6 mins) [Interaction of Earth, Moon and Sun]

# TOPIC OVERVIEW:

## Systems for Looking into Space

### Term 4, Weeks 5B – 6A

#### A. TOPIC OVERVIEW

##### Term 4, Weeks 5b – 6a

- This topic runs for 1 week.
- It is presented over 3 lessons.
- This topic counts for 12% in the end of year final exam.
- This topic's position in the term is as follows:

LESSON	WEEK 1			WEEK 2			WEEK 3			WEEK 4			WEEK 5		
		A	B	C	A	B	C	A	B	C	A	B	C	A	B

LESSON	WEEK 6			WEEK 7			WEEK 8			WEEK 9			WEEK 10		
		A	B	C	A	B	C	A	B	C	A	B	C	A	B

#### B. SEQUENTIAL TABLE

GRADE 5	GRADE 6	GRADE 6
<b>LOOKING BACK</b>	<b>CURRENT</b>	<b>LOOKING FORWARD</b>
<ul style="list-style-type: none"> <li>• Systems for going into space: rockets</li> </ul>	<ul style="list-style-type: none"> <li>• Telescopes: purpose; South Africa's large telescopes</li> </ul>	<ul style="list-style-type: none"> <li>• The historical development of astronomy</li> <li>• Early viewing of space</li> <li>• Telescopes</li> </ul>

### C. SCIENTIFIC AND TECHNOLOGICAL VOCABULARY

Ensure that you teach the following vocabulary at the appropriate place in the topic:

	TERM	EXPLANATION
1.	magnify	To make something look bigger
2.	observatory	A building with a strong telescope for looking at the planets and the stars
3.	antenna	A device that sends and receives radio or tv signals
4.	array	A large number of the same things
5.	square kilometre	An area in the shape of a square that with each side measuring 1 km
6.	galaxy	A group of many stars, along with gas and dust
7.	feint	Not clearly seen
8.	hexagonal	A shape with six sides

### D. UNDERSTANDING THE USES / VALUE OF SCIENCE

Telescopes allow us to see into space to discover new things about our Solar system, galaxies and beyond. South Africa has a perfect climate for viewing space and has built several very large telescopes that astronomers and scientists from all over the world come to use. The building of these telescopes has involved engineers, astronomers, scientists, information technologists, computer programmers and many others.

### E. PERSONAL REFLECTION

Reflect on your teaching at the end of each topic:

Date completed:	
Lesson successes:	
Lesson challenges:	
Notes for future improvement:	

## TOPIC: Systems for looking into space

# 5 B

**Term 4, Week 5, Lesson B**

**Lesson Title: Telescopes**

**Time for lesson: 1 hour**

### A POLICY AND OUTCOMES

<b>Sub-Topic</b>	Telescopes
<b>CAPS Page Number</b>	63

#### Lesson Objectives

By the end of the lesson, learners will be able to:

- explain the uses of a telescope
- describe how a lens magnifies images
- describe how a mirror reflects light

Specific Aims	1. DOING SCIENCE & TECHNOLOGY	✓
	2. KNOWING THE SUBJECT CONTENT & MAKING CONNECTIONS	✓
	3. UNDERSTANDING THE USES OF SCIENCES & INDIGENOUS KNOWLEDGE	✓

#### SCIENCE PROCESS SKILLS

1. Accessing & recalling Information	✓	7. Raising Questions		13. Interpreting Information	✓
2. Observing	✓	8. Predicting		14. Designing	
3. Comparing		9. Hypothesizing		15. Making/ constructing	
4. Measuring		10. Planning Investigations		16. Evaluating and improving products	
5. Sorting & Classifying		11. Doing Investigations		17. Communicating	✓
6. Identifying problems & issues		12. Recording Information	✓		



## TOPIC: Systems for looking into space

### B POSSIBLE RESOURCES

For this lesson, you will need:

IDEAL RESOURCES	IMPROVISED RESOURCES
A lens (magnifying glass)	A bottle or glass filled with water
A mirror	Make a mirror by sticking a foil chip packet onto cardboard with glue
Resource 23: An Observatory	
Resource 22: Galileo Galilei showing his telescope	

### C CLASSROOM MANAGEMENT

1. Make sure that you are ready and prepared.
2. Write the following question onto the chalkboard before the lesson starts:

True or False: The Moon rotates on its own axis and revolves around the Earth.

3. Learners should enter the classroom and answer the question in their workbooks.
4. Discuss the answer with the learners.
5. Write the model answer onto the chalkboard.

*True*

### D ACCESSING INFORMATION

1. Write the following onto the chalkboard (always try to do this before the lesson starts).

#### TELESCOPES

1. A telescope makes far away objects look closer.
2. Astronomers use telescopes to study the Solar System and other objects that are far away.
3. Telescopes use large lenses and mirrors to make objects seem closer.
4. Modern telescopes are large and have built in cameras to take photographs.
5. Large telescopes are put inside a building called an observatory.
6. This is a round building with high walls.
7. The observatory has a dome shaped roof that can slide open to view the night sky.

2. Explain this to the learners as follows:
  - a. Humans have been studying the night sky since the beginning of time.
  - b. A telescope is like a very big magnifying glass so it makes far away things look bigger.

## TOPIC: Systems for looking into space

- c. Observatories are placed in remote places so that the lights from cities and towns do not make the night sky too light.
3. Show learners Resource 23: 'An Observatory'. Point out the dome-shaped roof that can slide open.
4. Give learners some time to copy the information from the chalkboard into their workbooks.

### **Checkpoint 1**

Ask the learners the following questions to check their understanding at this point:

- a. What is an observatory?
- b. What do telescopes use to make objects look closer?

Answers to the checkpoint questions are as follows:

- a. A round building with high walls with a large telescope inside (the roof can open so that the night sky can be viewed).
- b. Lenses and mirrors.

## **E**

### **CONCEPTUAL DEVELOPMENT**

1. Read the following information to the learners:

Since the invention of the telescope, our knowledge of Space has grown enormously. Galileo Galilei, an Italian, made his own telescope in 1610. He used this telescope to study the night sky. Galilei was the first person to see the moons of Jupiter. He could prove that the Sun was at the centre of the Solar System. Galilei was put in prison when he told the authorities that it was the Sun that was at the centre of the Universe and not the Earth.
2. Show learners Resource 22: 'Galileo Galilei showing his telescope'.
3. **Activity: Lenses.** Do the following activity with the learners to show them what a lens can do.
  - a. Put learners into groups.
  - b. Each group must have a lens (either a hand-lens or round empty bottles filled with water).
  - c. One learner from each group must hold up the lens and look at something on the wall (some writing or a poster).
  - d. When the learner stands at a distance from the poster, the poster will appear to be upside down when it is looked at through the lens or bottle.
  - e. When the learner gets closer, the poster will be the right way up but it will look bigger than what it is. The lens is **magnifying** the poster.
4. **Activity: Mirrors.** Do the following activity with learners to show them the power of mirrors.
  - a. Put learners into groups.
  - b. Each group must have a mirror (either a small mirror or one that has been made with foil stuck to a piece of cardboard).

## TOPIC: Systems for looking into space

- c. Go outside into the sunshine.
  - d. A learner from each group must use a mirror to reflect sunlight onto a spot. Find a spot in the shade but the learners must be in the sun to reflect the sun off their mirrors.
  - e. All the learners with mirrors must reflect the light from the Sun onto the same spot.
  - f. Show learners that this spot will become very bright.
5. Go back to the classroom.
  6. Explain the following to the learners:
    - a. All the mirrors work together like one big mirrors onto a spot in the shade.
    - b. They each collect a bit of light energy from the Sun and send it to the spot that is bright.
    - c. This is how a telescope works.
    - d. The mirror inside a telescope collects the light from a star.
    - e. This light is focused on a lens.

### **Checkpoint 2**

Ask the learners the following questions to check their understanding at this point:

- a. Who was the Italian astronomer who made his own telescope in 1610?
- b. What word is used to mean 'to make something look bigger'?

Answers to the checkpoint questions are as follows:

- a. Galileo Galilei
- b. Magnify

7. Ask the learners if they have any questions and provide answers and explanations.

## TOPIC: Systems for looking into space

### F REFERENCE POINTS FOR FURTHER DEVELOPMENT

If you need additional information or activities on this topic, you can find these in your textbook on the following pages:

NAME OF TEXTBOOK	TOPIC	PAGE NUMBER
Study & Master	Systems for looking into space	160
Viva	Systems for looking into space	185-187
Platinum	Systems for looking into space	198
Solutions for All	Systems for looking into space	298-300
Day-by-Day	Systems for looking into space	180-181
Oxford	Systems for looking into space	130
Spot On	Systems for looking into space	85
Top Class	Systems for looking into space	136-137
Sasol Inzalo BkB	Systems for looking into space	182-187

### G ADDITIONAL ACTIVITIES / READING

In addition, further reading, listening or viewing activities related to this sub-topic are available through the following web links:

1. <https://goo.gl/ebgCQV> (1 min) [How to make a telescope at home]

## TOPIC: Systems for looking into space

# 5 C

### Term 4, Week 5, Lesson C

### Lesson Title: Telescopes

### Time for lesson: 1 hour

#### A POLICY AND OUTCOMES

<b>Sub-Topic</b>	South Africa's Telescopes
<b>CAPS Page Number</b>	63

#### Lesson Objectives

By the end of the lesson, learners will be able to:

- understand the relevance of building the SKA
- explain what the SKA consists of
- describe how powerful the SKA is

Specific Aims	1. DOING SCIENCE & TECHNOLOGY	
	2. KNOWING THE SUBJECT CONTENT & MAKING CONNECTIONS	✓
	3. UNDERSTANDING THE USES OF SCIENCES & INDIGENOUS KNOWLEDGE	

#### SCIENCE PROCESS SKILLS

1. Accessing & recalling Information	✓	7. Raising Questions		13. Interpreting Information	✓
2. Observing	✓	8. Predicting		14. Designing	
3. Comparing		9. Hypothesizing		15. Making/ constructing	
4. Measuring		10. Planning Investigations		16. Evaluating and improving products	
5. Sorting & Classifying		11. Doing Investigations		17. Communicating	✓
6. Identifying problems & issues		12. Recording Information	✓		

## TOPIC: Systems for looking into space

### B POSSIBLE RESOURCES

For this lesson, you will need:

IDEAL RESOURCES	IMPROVISED RESOURCES
Resource 25: The Square Kilometre Array	A bottle or glass filled with water

### C CLASSROOM MANAGEMENT

1. Make sure that you are ready and prepared.
2. Write the following question onto the chalkboard before the lesson starts:

What does a telescope do?

3. Learners should enter the classroom and answer the question in their workbooks.
4. Discuss the answer with the learners.
5. Write the model answer onto the chalkboard.

*A telescope lets us see objects, far away in space, that we would not be able to see with our naked eye.*

### D ACCESSING INFORMATION

1. Write the following onto the chalkboard (always try to do this before the lesson starts).

#### THE SKA TELESCOPE

- a. South Africa has built, and uses, some of the largest telescopes on the Earth.
- b. The **Square Kilometre Array** (SKA) radio telescope is going to be the world's largest telescope.
- c. The SKA will be made up of over 4 000 (four thousand) dish-shaped **antenna**.
- d. These are spread over an area of 3 000 kilometres.
- e. Most of the antennas are being built near Carnarvon in the Northern Cape.
- f. These antennas are in the shape of dishes.
- g. These dishes will collect radio-waves from faraway objects.
- h. The dishes will send their information to one super computer.
- i. The computer will change this information into images and data.
- j. Scientists will study these images and data.

2. Explain this to the learners as follows:
  - a. Astronomers come from all over the world come to use South Africa's telescopes.
  - b. The SKA will have an **array** of several thousand antennas (dishes).
  - c. An array means a large number of the same things.
  - d. The antenna (dishes) look like the satellite TV dishes that you see on some people's houses.

## TOPIC: Systems for looking into space

- e. Most of the dishes will be near Carnarvon in the Northern Cape, others will be in Ghana, Zambia, Mozambique and Madagascar.
  - f. The SKA project will be completed in 2024.
3. Give learners some time to copy the information from the chalkboard into their workbooks.

### **Checkpoint 1**

Ask the learners the following questions to check their understanding at this point:

- a. What does SKA stand for?
- b. What is an 'array'?

Answers to the checkpoint questions are as follows:

- a. Square Kilometre Array
- b. An array is a large number of the same things

## **E** CONCEPTUAL DEVELOPMENT

1. Read the following information to the learners:

The light waves from stars or **galaxies** very far away take a long time to travel through space to our telescopes. We see them as they were a very long time ago. Astronomers are building very powerful telescopes to see back to when stars and galaxies were made. The SKA is a giant telescope that will give scientists information and images (pictures) to assist them with their studies.

The MeerKat telescope is being built first. This will have seven antenna (dishes). It will be the most powerful telescope in the world until the SKA is built. The super computer that will collect all the data (information) from the dishes will have the processing power of 100 million home computers. It will collect huge amounts of data. One day's data would take two years to play back using an iPod.

2. Write the following onto the chalkboard (answers are in italics). Ask the learners to write out the four sentences and choose the correct word from the list, to complete the sentences. They must underline the correct word.

### THE SKA

4000, super, radio, largest

- a. The SKA is a \_\_\_\_ telescope. (*radio*)
- b. The SKA will be the world's \_\_\_\_ telescope when it is built. (*largest*)
- c. It is made up of over \_\_\_\_ antennas (dishes). (*4000*)
- d. These antenna (dishes) send data to a \_\_\_\_ computer. (*super*)

## TOPIC: Systems for looking into space

3. If you have time, download the following comic books about an inquisitive school girl, Hannah, and a young astronomer, Naledi. The stories help readers understand how radio astronomy works and why most of the SKA will be built in the Karoo.  
<http://www.ska.ac.za/outreach/mission-meerkat/>

### **Checkpoint 2**

Ask the learners the following questions to check their understanding at this point:

- Why do astronomers want to build very powerful telescopes?
- Which country will have the world's largest telescopes?

Answers to the checkpoint questions are as follows:

- To see back to when stars and galaxies were formed.
- South Africa

4. Ask the learners if they have any questions and provide answers and explanations.

## **F** REFERENCE POINTS FOR FURTHER DEVELOPMENT

If you need additional information or activities on this topic, you can find these in your textbook on the following pages:

NAME OF TEXTBOOK	TOPIC	PAGE NUMBER
Study & Master	Systems for looking into space	162
Viva	Systems for looking into space	193-194
Platinum	Systems for looking into space	204-205
Solutions for All	Systems for looking into space	304-306
Day-by-Day	Systems for looking into space	182-183
Oxford	Systems for looking into space	-
Spot On	Systems for looking into space	89
Top Class	Systems for looking into space	138-139
Sasol Inzalo BkB	Systems for looking into space	188-190

## **G** ADDITIONAL ACTIVITIES / READING

In addition, further reading, listening or viewing activities related to this sub-topic are available through the following web links:

- <https://goo.gl/rLPjvh> (2 mins) [South Africa's Meerkat Telescope]
- <https://goo.gl/x7jqu9> (2 1/2 mins) [South African SKA Telescope]
- <https://goo.gl/boSmnd> (2 1/2 mins) [Square Kilometre Array Official Animation]



## TOPIC: Systems for looking into space

# 6 A

### Term 4, Week 6, Lesson A

### Lesson Title: Telescopes

### Time for lesson: 1 hour

## A POLICY AND OUTCOMES

<b>Sub-Topic</b>	More about South Africa's Telescopes
<b>CAPS Page Number</b>	63

### Lesson Objectives

By the end of the lesson, learners will be able to:

- describe an optical telescope
- explain why SALT was built in Sutherland
- explain the importance of the SALT telescope to scientists and astronomers

Specific Aims	1. DOING SCIENCE & TECHNOLOGY	
	2. KNOWING THE SUBJECT CONTENT & MAKING CONNECTIONS	✓
	3. UNDERSTANDING THE USES OF SCIENCES & INDIGENOUS KNOWLEDGE	

### SCIENCE PROCESS SKILLS

1. Accessing & recalling Information	✓	7. Raising Questions	✓	13. Interpreting Information	✓
2. Observing	✓	8. Predicting		14. Designing	
3. Comparing	✓	9. Hypothesizing		15. Making/ constructing	
4. Measuring		10. Planning Investigations		16. Evaluating and improving products	
5. Sorting & Classifying		11. Doing Investigations		17. Communicating	✓
6. Identifying problems & issues		12. Recording Information			

## TOPIC: Systems for looking into space

### B POSSIBLE RESOURCES

For this lesson, you will need:

IDEAL RESOURCES	IMPROVISED RESOURCES
Resource 26: The South African Large Telescope	
Resource 27: The Mirror inside SALT	
Resource 28: An image taken at SALT	

### C CLASSROOM MANAGEMENT

1. Make sure that you are ready and prepared.
2. Write the following question onto the chalkboard before the lesson starts:

What type of telescope is the SKA?

3. Learners should enter the classroom and answer the question in their workbooks.
4. Discuss the answer with the learners.
5. Write the model answer onto the chalkboard.

*It is a radio telescope*

### D ACCESSING INFORMATION

1. Write the following onto the chalkboard (always try to do this before the lesson starts).

#### SALT – A LARGE OPTICAL TELESCOPE

- a. SALT stands for Southern African Large Telescope.
- b. SALT is an optical telescope.
- c. An optical telescope uses mirrors to catch light waves from objects in space.
- d. It is in Sutherland in the Karoo, Northern Cape.
- e. The sky there is dark and clear at night.
- f. Weather conditions are good.
- g. SALT can detect the light from far away objects.

2. Explain this to the learners as follows:
  - a. The SALT telescope is very powerful.
  - b. The SALT is the same size as the largest telescope in the world.
  - c. It is an optical telescope.
  - d. An optical telescope uses mirrors to catch light waves from objects in space.
  - e. It can detect (see) very faint and distant objects.

## TOPIC: Systems for looking into space

- f. It can detect objects as faint as a candle flame on the Moon.
  - g. The SALT was built just outside Sutherland. There are no city or town lights nearby to disturb the telescope.
3. Show the learners Resource 26: 'The Southern African Large Telescope'. Show learners the dome- shaped roof. Explain that this roof opens for the telescope to be focused into space.
  4. Give learners some time to copy the information from the chalkboard into their workbooks.

### **Checkpoint 1**

Ask the learners the following questions to check their understanding at this point:

- a. What does SALT stand for?
- b. Why is Sutherland a good place to put a large telescope?

Answers to the checkpoint questions are as follows:

- a. Southern African Large Telescope.
- b. It has a dark, clear sky and the weather conditions are good.

## **E**

### **CONCEPTUAL DEVELOPMENT**

#### **THE SALT**

The SALT works with huge **arrays** of small mirrors. These small mirrors reflect the light from **faint** objects in space. SALT has 91 **hexagonal** mirrors that fit together to make one big mirror. This mirror measures 11 metres across. The telescope **magnifies** images many times until they are visible to the naked eye. Scientists from all over the world come SALT to study objects in space.

2. Show learners Resource 27: 'The Mirrors inside SALT'. Explain to the learners that these mirrors reflect the light from objects in space.
3. Show learners Resource 28: 'An image taken at SALT'. Explain to learners that the telescope can take images of objects in space which helps scientists to study planets, stars, **galaxies** and other objects.
4. Write the following sentences on the chalkboard. In their workbooks, learners must say whether the sentences are true or false. If the sentence is false, the learners must write a correct sentence.

## TOPIC: Systems for looking into space

### THE SALT

- a. SALT is a radio telescope.
- b. SALT was built in Sutherland.
- c. SALT uses 91 small mirrors to reflect light from faint objects in space.
- d. Only South African scientists can study objects in space using the SALT telescope.

Answers:

- a. False. SALT is an optical telescope.
- b. True.
- c. True.
- d. False. Scientists from all over the world can study objects in space using the SALT telescope.

5. Ask the learners if they have any questions and provide answers and explanations.

### **Checkpoint 2**

Ask the learners the following questions to check their understanding at this point:

- a. What type of telescope is SALT?
- b. What does this type of telescope use to catch light waves from space?

Answers to the checkpoint questions are as follows:

- a. An optical telescope
- b. It uses mirrors

6. Ask the learners if they have any questions and provide answers and explanations.

## TOPIC: Systems for looking into space

### F REFERENCE POINTS FOR FURTHER DEVELOPMENT

If you need additional information or activities on this topic, you can find these in your textbook on the following pages:

NAME OF TEXTBOOK	TOPIC	PAGE NUMBER
Study & Master	Systems for looking into space	161
Viva	Systems for looking into space	-
Platinum	Systems for looking into space	204
Solutions for All	Systems for looking into space	303-304
Day-by-Day	Systems for looking into space	182
Oxford	Systems for looking into space	131
Spot On	Systems for looking into space	-
Top Class	Systems for looking into space	137
Sasol Inzalo BkB	Systems for looking into space	184

### G ADDITIONAL ACTIVITIES / READING

In addition, further reading, listening or viewing activities related to this sub-topic are available through the following web links:

1. <https://goo.gl/9i6kio> (4 min) [South Africa's SALT Telescope]
2. <https://goo.gl/H4esoE> (1/2 min) [SALT by Drive]

# TOPIC OVERVIEW:

## Planet Earth and Beyond

### Term 4, Weeks 6B – 8C

#### A. TOPIC OVERVIEW

##### Term 4, Weeks 1a – 3a

- This topic runs for 2 ½ weeks.
- This topic counts for 32% in the end of year final exam.
- It is presented over 8 lessons.
- This topic's position in the term is as follows:

LESSON	WEEK 1			WEEK 2			WEEK 3			WEEK 4			WEEK 5		
	A	B	C	A	B	C	A	B	C	A	B	C	A	B	C
LESSON	WEEK 6			WEEK 7			WEEK 8			WEEK 9			WEEK 10		
	A	B	C	A	B	C	A	B	C	A	B	C	A	B	C

#### B. SEQUENTIAL TABLE

GRADE 5	GRADE 6	GRADE 6
<b>LOOKING BACK</b>	<b>CURRENT</b>	<b>LOOKING FORWARD</b>
<ul style="list-style-type: none"> <li>• Design, make and evaluate a rocket</li> <li>• Understand propulsion using exhaust gas</li> </ul>	<ul style="list-style-type: none"> <li>• Know about the surface of the Moon and how vehicles are designed to move around the Moon</li> <li>• Learn about the robots that have visited Mars</li> <li>• Understand how wheels, axles, mechanical arms, systems for solar energy production, communication methods enable us to find out about Mars</li> <li>• Design, make and evaluate models</li> <li>• Measure distances and draw graphs</li> </ul>	

## C. SCIENTIFIC AND TECHNOLOGICAL VOCABULARY

Ensure that you teach the following vocabulary at the appropriate place in the topic:

	TERM	EXPLANATION
1.	Moon rover	A vehicle for travelling on mars to collect soil and take photographs
2.	astronauts	People who travel in space
2.	extreme temperatures	Temperatures that are very cold or very hot
4.	lunar	Relating to the moon; we talk about the 'lunar landing' which was the first landing on the moon
5.	navigate	To find your way, often using maps or instruments
6.	durable	Made to last a long time; the product won't tear or wear away easily
7.	stable	An object is stable if it will not topple over easily, it will remain in an upright position
8.	decade	A period of ten years
9.	in operation	In use
10.	diameter	The distance from the outside of circle, through the centre, to the opposite side
11.	chevron	A shape or pattern in the form of a v; a series of v shapes
12.	NASA	An acronym for national aeronautics and space administration; it is based in the usa
13.	solar energy	Energy from the sun which is converted into electrical energy
14.	chassis	The frame of a vehicle to which wheels and axles, steering, the body, the engine and other parts are attached
15.	potential energy	The energy an object has because of its position, rather than its movement. An object held in a person's hand has potential energy, which turns to kinetic energy — the energy of motion — when the person lets it go, and it drops to the ground.
16.	drill	A tool used for making holes
17.	scoop	A tool that looks like a big spoon
18.	sieves	To separate small particles from big ones by putting solids through a wire mesh
19.	analysis	Looking at separate parts of something in detail

## D. UNDERSTANDING THE USES / VALUE OF SCIENCE

Engineers would be involved in designing special vehicles to travel in space. Astronauts would have to practice driving on Earth in their Astronaut Suits to test the vehicles before they could be used on the Moon.

## E. PERSONAL REFLECTION

Reflect on your teaching at the end of each topic:

Date completed:

Lesson successes:

Lesson challenges:

Notes for future improvement:



**6 B**

**Term 4, Week 6, Lesson B**

**Lesson Title: Vehicles used on the Moon; Vehicles used on Mars**

**Time for lesson: 1½ hours**

**A POLICY AND OUTCOMES**

<b>Sub-Topic</b>	How to get around on the Moon and Mars
<b>CAPS Page Number</b>	64

**Lesson Objectives**

By the end of the lesson, learners will be able to:

- explain the special needs of vehicles travelling on the Moon
- explain the special needs of vehicles travelling on Mars
- describe some of the equipment the rovers carry

Specific Aims	1. DOING SCIENCE & TECHNOLOGY	
	2. KNOWING THE SUBJECT CONTENT & MAKING CONNECTIONS	✓
	3. UNDERSTANDING THE USES OF SCIENCES & INDIGENOUS KNOWLEDGE	

**SCIENCE PROCESS SKILLS**

1. Accessing & recalling Information	✓	7. Raising Questions		13. Interpreting Information	✓
2. Observing	✓	8. Predicting		14. Designing	
3. Comparing		9. Hypothesizing		15. Making/ constructing	
4. Measuring		10. Planning Investigations		16. Evaluating and improving products	
5. Sorting & Classifying		11. Doing Investigations		17. Communicating	✓
6. Identifying problems & issues		12. Recording Information	✓		

## TOPIC: Systems to explore the Moon and Mars

### B POSSIBLE RESOURCES

For this lesson, you will need:

IDEAL RESOURCES	IMPROVISED RESOURCES
Resource 31: The Curiosity	

### C CLASSROOM MANAGEMENT

1. Make sure that you are ready and prepared.
2. Write the following question onto the chalkboard before the lesson starts:

What is South Africa's largest optical telescope called?

3. Learners should enter the classroom and answer the question in their workbooks.
4. Discuss the answer with the learners.
5. Write the model answer onto the chalkboard.

*It is called the SALT: Southern Africa Large Telescope*

### D ACCESSING INFORMATION

1. Write the following onto the chalkboard (always try to do this before the lesson starts).

#### VEHICLES USED TO EXPLORE THE MOON

1. A **moon rover** is a vehicle designed to drive on the surface of the Moon.
2. It is known as a **Lunar** Roving Vehicle (LRV).
3. It would have to work in extreme temperatures.
4. The LVR would have to carry **two astronauts**.
5. Astronauts need rovers as their spacesuits are very heavy.

#### VEHICLES USED TO EXPLORE MARS

1. All Mars rovers are robots.
2. Mars rovers need to land very carefully as there is a lot of dust on Mars.
3. Mars rovers are controlled from Earth.
4. 'Curiosity', a Mars rover, has been there since 2012.
5. It cost \$2.5 billion to build
6. 'Curiosity' has 17 cameras and many scientific instruments.
7. It has a set of tools at the end of its robotic arm.
8. 'Curiosity' has sent back hundreds of images (pictures) and lots of data (information).

## TOPIC: Systems to explore the Moon and Mars

2. Explain the section on 'Vehicles used to explore the Moon' to the learners as follows:
  - a. In a previous lesson (Lesson 3A), you heard about a man called Neil Armstrong walking on the Moon in 1969.
  - b. The spacecraft for this mission was called Apollo 11.
  - c. In 1971, astronauts who travelled to the Moon used vehicles with special wheels and axles to get around.
  - d. These vehicles are called Lunar Roving Vehicles (LRVs).
  - e. They have to work in temperatures ranging from  $-153^{\circ}\text{C}$  to  $153^{\circ}\text{C}$ .
  - f. The LVR would have to fold up to fit inside the spacecraft.
  - g. It would have to carry two astronauts.
3. Give learners some time to copy the information on 'Vehicles used to explore the Moon' into their workbooks.
4. Explain the section on 'Vehicles used to explore the Mars' to the learners as follows:
  - a. Mars is very different from Earth so the rovers have to be designed and built very well.
  - b. It is very dusty on Mars so the rovers have to be designed so that dust cannot get into their systems.
  - c. Mars rovers are very expensive to build.
  - d. Each rover has several cameras.
  - e. Some cameras are used to help the rover **navigate** the surface of Mars.
  - f. Rovers travel about 100 metres per day.
  - g. They collect information about the soil and rocks as they go.
  - h. Rovers have heaters to keep their batteries warm as it gets very cold on Mars.
  - i. Rovers stay on Mars and gather information for many years.
5. Give learners some time to copy the information on 'Vehicles used to explore Mars' into their workbooks.

### **Checkpoint 1**

Ask the learners the following questions to check their understanding at this point:

- a. What does LRV stand for?
- b. How many cameras does 'Curiosity' have?

Answers to the checkpoint questions are as follows:

- a. Lunar Roving Vehicle
- b. 17

## TOPIC: Systems to explore the Moon and Mars

### E

### CONCEPTUAL DEVELOPMENT

1. Show learners Resource 31: 'The Curiosity'. Point out the mechanical arm and the camera.
2. Read the following sentences to the learners. Ask to the learners to listen carefully, as they will be asked to write two sentences on what the 'Curiosity' is designed to do on Mars.
  - a. Curiosity examines rocks on Mars with a set of tools at the end of its arm.
  - b. These arms can extend to about two metres.
  - c. A **drill** collects samples from inside rocks.
  - d. A **scoop** picks up samples of soil.
  - e. The arm **sieves** the samples and delivers the fine sand to instruments inside the rover for **analysis**.
3. Explain this task to the learners as follows:
  - a. Write two sentences into your workbook in which you describe what this rover is designed to do.
4. Give learners some time to complete this task in their workbooks.
5. Possible sentences are:

*The Curiosity can drill into rocks.*

*It can take samples from inside rocks.*

*It can scoop soil.*

*It can sieve soil.*

*It can analyse soil samples.*

#### **Checkpoint 2**

Ask the learners the following questions to check their understanding at this point:

- a. What is the name of the Mars rover that has been on Mars since 2012?
- b. Why does this rover have a drill?

Answers to the checkpoint questions are as follows:

- a. The Curiosity
- b. So it can collect samples from inside rocks

## TOPIC: Systems to explore the Moon and Mars

### F REFERENCE POINTS FOR FURTHER DEVELOPMENT

If you need additional information or activities on this topic, you can find these in your textbook on the following pages:

NAME OF TEXTBOOK	TOPIC	PAGE NUMBER
Study & Master	Systems to explore the Moon and Mars	163-164
Viva	Systems to explore the Moon and Mars	197-200
Platinum	Systems to explore the Moon and Mars	207-211
Solutions for All	Systems to explore the Moon and Mars	310-314
Day-by-Day	Systems to explore the Moon and Mars	186-187
Oxford	Systems to explore the Moon and Mars	132
Spot On	Systems to explore the Moon and Mars	90-91
Top Class	Systems to explore the Moon and Mars	140-143
Sasol Inzalo BkB	Systems to explore the Moon and Mars	158

### G ADDITIONAL ACTIVITIES / READING

In addition, further reading, listening or viewing activities related to this sub-topic are available through the following web links:

1. <https://goo.gl/nmCreM> (2½ mins) [Apollo 16 LRV]
2. <https://goo.gl/D5Cd5a> (3 mins) [Mars Rovers Seven Minutes of Terror]
3. <https://goo.gl/gcYXhZ> (25 mins) [The Curious Life of a Mars Rover]
4. <http://www.telegraph.co.uk/science/2017/08/03/nasas-curiosity-rover-will-celebrate-five-years-mars-lonely/>

## TOPIC: Systems to explore the Moon and Mars

# 6 C

### Term 4, Week 6, Lesson C

### Lesson Title: Vehicles used on Mars and the Moon

### Time for lesson: 1½ hours

#### A POLICY AND OUTCOMES

<b>Sub-Topic</b>	Wheels and axles
<b>CAPS Page Number</b>	64

#### Lesson Objectives

By the end of the lesson, learners will be able to:

- explain the need for different types of wheels depending on the environment
- design and make wheels and axles
- compare fixed and turning axles
- draw and label the frame of a rover with wheels and axles

Specific Aims	1. DOING SCIENCE & TECHNOLOGY	✓
	2. KNOWING THE SUBJECT CONTENT & MAKING CONNECTIONS	✓
	3. UNDERSTANDING THE USES OF SCIENCES & INDIGENOUS KNOWLEDGE	

#### SCIENCE PROCESS SKILLS

1. Accessing & recalling Information	✓	7. Raising Questions		13. Interpreting Information	✓
2. Observing	✓	8. Predicting		14. Designing	✓
3. Comparing		9. Hypothesizing		15. Making/ constructing	✓
4. Measuring		10. Planning Investigations		16. Evaluating and improving products	
5. Sorting & Classifying		11. Doing Investigations	✓	17. Communicating	
6. Identifying problems & issues	✓	12. Recording Information	✓		

## TOPIC: Systems to explore the Moon and Mars

### B POSSIBLE RESOURCES

For this lesson, you will need:

IDEAL RESOURCES	IMPROVISED RESOURCES
Resource 29: The Moon Rover's Wheel	
Resource 30: The Curiosity's Wheel	
Resource 31: A Mars Rover: The Curiosity	
Resource 32: How to make wheels and axles	
Resource 33: How to fix axles onto a frame of a rover	
Resource 34: Find the centre	
Resource 35: Stoppers and Spacers	

### C CLASSROOM MANAGEMENT

1. Make sure that you are ready and prepared.
2. Write the following question onto the chalkboard before the lesson starts:

True or False: Mars rovers are controlled from Earth.

3. Learners should enter the classroom and answer the question in their workbooks.
4. Discuss the answer with the learners.
5. Write the model answer onto the chalkboard.

*True. (They are robots)*

### D ACCESSING INFORMATION

1. Read the following to the learners:

#### WHEELS OF MARS ROVERS

**NASA** has sent four rovers to Mars in the last **decade**. Two are still in **operation**. The rovers travel around Mars for many years, therefore the wheels have to be **durable**. Each wheel on Curiosity is 51 cm in **diameter**. The wheels have a **chevron** design. This is so the rover can travel on sandy and rocky surfaces. Curiosity has six wheels to keep it **stable**.

2. Explain this to the learners as follows:
  - a. Two of the four rovers sent to Mars are still in operation. This means that their wheels have to be durable.
  - b. The chevron design on the wheels is so that the wheels can grip rocks and keep going in sand. Show learners Resource 30: 'The Curiosity's Wheels'.

## TOPIC: Systems to explore the Moon and Mars

- c. The number of wheels makes it stable. Show learners Resource 31: 'The Mars Rover: The Curiosity'. Point out the number of wheels on the rover.

### **Checkpoint 1**

Ask the learners the following questions to check their understanding at this point:

- a. What does 'durable' mean?
- b. Why does the 'Curiosity' have six wheels?

Answers to the checkpoint questions are as follows:

- a. To last a long time
- b. To keep it stable

## **E**

### **CONCEPTUAL DEVELOPMENT**

1. Write the following onto the chalkboard (always try to do this before the lesson starts):

#### SUMMARY OF MAKING WHEELS AND AXLES

1. The axle must go through the centre of the wheel.
2. Axles can be fixed and wheels free to turn or the axle can turn with the wheels fixed to it.
3. Axles must have a spacer between the wheel and the frame of a rover.
4. Axles must have stoppers to prevent the wheels from falling off.

2. Show learners Resource 32: 'How to make wheels and axles'.
3. Explain the following to the learners, about making wheels and axles:
  - a. Wheels fit onto axles.
  - b. Axles are a solid rod or bar that join the wheels allowing them to turn.
  - c. There are two ways in which an axle and wheels work:
    - the axle can either be fixed (the axle does not turn but the wheels turn)

OR

  - the axle can be free-turning (the axle does turn but the wheels are fixed).
  - d. Wheels can be made from many circular objects, such as bottle tops, CDs, small paper plates, cardboard.
  - e. The axle needs to go through the centre of the wheel. Show learners Resource 34: 'Finding the centre of a wheel'.
  - f. Show learners Resource 35: 'Stoppers and Spacers'. Show the learners the spacers in the first diagram. A spacer needs to be attached onto the axle, between the frame of a rover and the wheel:
    - this creates a space between the frame of a rover and the wheels
    - you can use any object like a bead, card, piece of tape, elastic bands.
  - g. The two axles on a frame of a rover need to be parallel for the vehicle to go straight.



## TOPIC: Systems to explore the Moon and Mars

4. Give learners some time to copy the information on the chalkboard into their workbooks.
5. Ask learners to draw a frame of a rover with two axles and wheels. Learners must:
  - draw neatly
  - label the following on the diagram: frame of a rover, axle, wheel, stopper, spacer
  - give your drawing a title

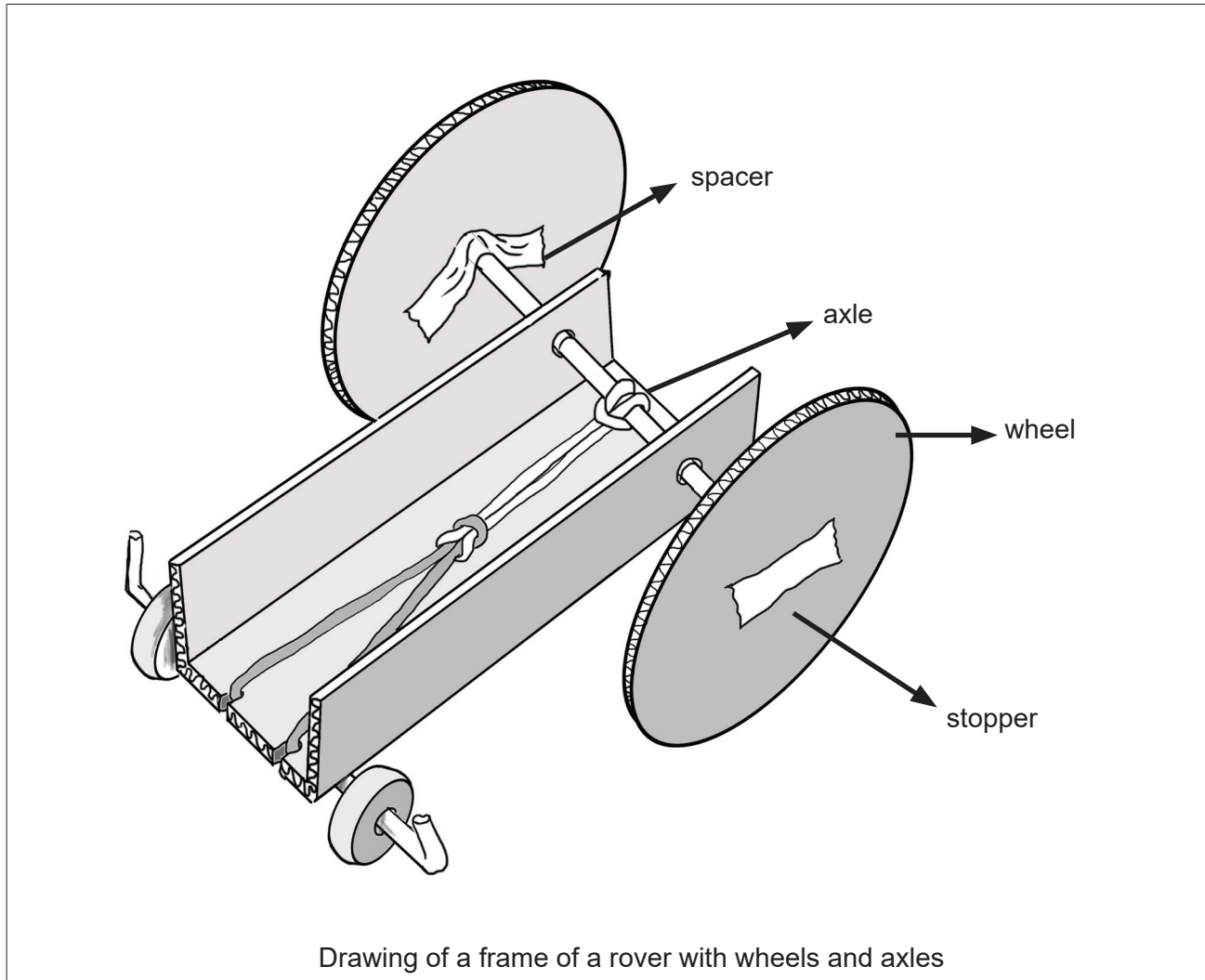

6. Ask the learners to start looking for objects that would be suitable for wheels and axles, like bottle tops, old CDs, rods, etc.

### **Checkpoint 2**

Ask the learners the following questions to check their understanding at this point:

- a. True or False: If an axle is fixed then the wheels must turn freely.
- b. True or False: A Mars vehicle is called a rover.

Answers to the checkpoint questions are as follows:

- a. True
- b. True

7. Ask the learners if they have any questions and provide answers and explanations.

## TOPIC: Systems to explore the Moon and Mars

### F REFERENCE POINTS FOR FURTHER DEVELOPMENT

If you need additional information or activities on this topic, you can find these in your textbook on the following pages:

NAME OF TEXTBOOK	TOPIC	PAGE NUMBER
Study & Master	Systems to explore the Moon and Mars	167-169
Viva	Systems to explore the Moon and Mars	-
Platinum	Systems to explore the Moon and Mars	213
Solutions for All	Systems to explore the Moon and Mars	323
Day-by-Day	Systems to explore the Moon and Mars	190
Oxford	Systems to explore the Moon and Mars	-
Spot On	Systems to explore the Moon and Mars	-
Top Class	Systems to explore the Moon and Mars	142
Sasol Inzalo BkB	Systems to explore the Moon and Mars	165-168

### G ADDITIONAL ACTIVITIES / READING

In addition, further reading, listening or viewing activities related to this sub-topic are available through the following web links:

1. <https://www.sciencefriday.com/segments/to-build-a-wheel-that-lasts-test-on-mars/>
2. <https://goo.gl/CndtoC> (1 1/2 mins) [Special wheels on Mars Curiosity Rover]
3. <https://goo.gl/YXwyUc> (1 1/2 mins) [Wheel and Axle]
4. <https://goo.gl/vSoGVF> (14 1/2 mins) [How to make a rubber band powered car]

## TOPIC: Systems to explore the Moon and Mars

# 7 A

### Term 4, Week 7, Lesson A

### Lesson Title: Vehicles used to explore the Moon; vehicles used to explore Mars

Time for lesson: 1 hour

#### A POLICY AND OUTCOMES

<b>Sub-Topic</b>	How Rovers move on the Moon and Mars
<b>CAPS Page Number</b>	64

#### Lesson Objectives

By the end of the lesson, learners will be able to:

- explain how the first rovers used solar energy
- explain how potential energy is converted into kinetic energy

Specific Aims	1. DOING SCIENCE & TECHNOLOGY	
	2. KNOWING THE SUBJECT CONTENT & MAKING CONNECTIONS	✓
	3. UNDERSTANDING THE USES OF SCIENCES & INDIGENOUS KNOWLEDGE	

#### SCIENCE PROCESS SKILLS

1. Accessing & recalling Information	✓	7. Raising Questions		13. Interpreting Information	✓
2. Observing	✓	8. Predicting		14. Designing	✓
3. Comparing		9. Hypothesizing	✓	15. Making/ constructing	
4. Measuring		10. Planning Investigations		16. Evaluating and improving products	
5. Sorting & Classifying		11. Doing Investigations	✓	17. Communicating	✓
6. Identifying problems & issues		12. Recording Information	✓		

## TOPIC: Systems to explore the Moon and Mars

### B POSSIBLE RESOURCES

For this lesson, you will need:

IDEAL RESOURCES	IMPROVISED RESOURCES
Resource 36: The Spirit's Solar Panels	
Resource 37: Potential Energy	
Resource 38: A Rocket Car	

### C CLASSROOM MANAGEMENT

1. Make sure that you are ready and prepared.
2. Write the following question onto the chalkboard before the lesson starts:

Why does a system of wheels and an axle have to have a stopper?

3. Learners should enter the classroom and answer the question in their workbooks.
4. Discuss the answer with the learners.
5. Write the model answer onto the chalkboard.

*Stoppers prevent the wheels from falling off the axles.*

### D ACCESSING INFORMATION

1. Write the following onto the chalkboard (always try to do this before the lesson starts):

#### HOW TO MOVE ON THE MOON AND MARS

- a. The first rovers used electrical motors, one for each wheel.
- b. These rovers used solar panels as their energy source for these motors.
- c. These panels converted **solar energy** into electrical energy.
- d. Solar panels are known as photovoltaic cells.
- e. 'Curiosity' uses nuclear power.

#### OTHER TYPES OF ENERGY

- a. Stored energy is called **potential energy**.
- b. Movement energy is called kinetic energy.

2. Explain this to the learners as follows:
  - a. The rover on the moon had four electrical motors, one for each wheel.
  - b. Show the learners Resource 36: 'The Spirit's Solar Panels'. Point out the solar panels on the top of this rover.
  - c. Remind the learners that in Grade 5 they explored different types of energy by stretching an elastic band and compressing springs. When you stretch the elastic band, you give the elastic band potential energy. When you compress the spring, you give the spring potential energy.

## TOPIC: Systems to explore the Moon and Mars

3. Give learners some time to copy this information into their exercise books.

### **Checkpoint 1**

Ask the learners the following questions to check their understanding at this point:

- a. What type of energy does a stretched elastic band have?
- b. What type of energy did the first rovers on Mars use?

Answers to the checkpoint questions are as follows:

- a. Potential energy
- b. Solar energy

## **E**

### **CONCEPTUAL DEVELOPMENT**

1. Demonstrate the following to the learners:

Stretch an elastic band. Explain that when it is stretched, it has stored energy known as **potential energy**. When you let the elastic band go, it will move. Potential energy has been changed (converted) into movement energy (**kinetic energy**). A rover could be made to move if both ends of an elastic band were tied to both axles, and one axle was turned to stretch the elastic. When the axle is let go, the potential energy would change to kinetic energy. This would move the rover forward.

2. Show learners Resource 37: 'Potential Energy'. Explain that you can give a vehicle potential energy by lifting a ramp up off the ground. The vehicle will then move when you let it go. Potential energy has been changed (converted) to kinetic energy (movement energy). Explain to learners that when they make their own rover, it will have to move on a flat surface too.
3. Explain to learners that there is another way to get a vehicle to move. This is to make a rocket (learners made a rocket in Grade 4). Inside the rocket, gas pushes against all sides and some gas pushes out through the bottom of the rocket. Show learners Resource 38: 'A Rocket Car'. A balloon could be used to make a rocket.

### **Checkpoint 2**

Ask the learners the following questions to check their understanding at this point:

- a. What is another word for movement energy?
- b. What does a rocket use to give it kinetic energy?

Answers to the checkpoint questions are as follows:

- a. Kinetic energy
- b. Gas

4. Ask the learners if they have any questions and provide answers and explanations.

## TOPIC: Systems to explore the Moon and Mars

### F REFERENCE POINTS FOR FURTHER DEVELOPMENT

If you need additional information or activities on this topic, you can find these in your textbook on the following pages:

NAME OF TEXTBOOK	TOPIC	PAGE NUMBER
Study & Master	Systems to explore the Moon and Mars	165-167
Viva	Systems to explore the Moon and Mars	203
Platinum	Systems to explore the Moon and Mars	-
Solutions for All	Systems to explore the Moon and Mars	326
Day-by-Day	Systems to explore the Moon and Mars	190
Oxford	Systems to explore the Moon and Mars	-
Spot On	Systems to explore the Moon and Mars	-
Top Class	Systems to explore the Moon and Mars	145
Sasol Inzalo BkB	Systems to explore the Moon and Mars	163-165

### G ADDITIONAL ACTIVITIES / READING

In addition, further reading, listening or viewing activities related to this sub-topic are available through the following web links:

## TOPIC: Systems to explore the Moon and Mars

# 7 B

### Term 4, Week 7, Lesson B

### Lesson Title: Design a Rover

### Time for lesson: 1 hour

#### A POLICY AND OUTCOMES

<b>Sub-Topic</b>	The Sun, Planets and Asteroids
<b>CAPS Page Number</b>	64

#### Lesson Objectives

By the end of the lesson, learners will be able to:

- write design briefs, specifications and constraints
- sketch design ideas
- apply existing knowledge to solve problems

Specific Aims	1. DOING SCIENCE & TECHNOLOGY	✓
	2. KNOWING THE SUBJECT CONTENT & MAKING CONNECTIONS	
	3. UNDERSTANDING THE USES OF SCIENCES & INDIGENOUS KNOWLEDGE	✓

#### SCIENCE PROCESS SKILLS

1. Accessing & recalling Information	✓	7. Raising Questions		13. Interpreting Information	✓
2. Observing		8. Predicting		14. Designing	✓
3. Comparing		9. Hypothesizing		15. Making/ constructing	✓
4. Measuring		10. Planning Investigations		16. Evaluating and improving products	
5. Sorting & Classifying		11. Doing Investigations	✓	17. Communicating	
6. Identifying problems & issues	✓	12. Recording Information	✓		

## TOPIC: Systems to explore the Moon and Mars

### B POSSIBLE RESOURCES

For this lesson, you will need:

IDEAL RESOURCES	IMPROVISED RESOURCES
Resource 32: How to make wheels and axles	
Resource 33: How to fix axles onto a frame of the rover	
Resource 34: Finding the centre of a wheel	
Resource 35: Stoppers and spacers	
Resource 39: Elastic Bands and axles	

### C CLASSROOM MANAGEMENT

1. Make sure that you are ready and prepared.
2. Write the following question onto the chalkboard before the lesson starts:

What do we call energy that is stored?

3. Learners should enter the classroom and answer the question in their workbooks.
4. Discuss the answer with the learners.
5. Write the model answer onto the chalkboard.

*Potential energy*

### D ACCESSING INFORMATION

1. Write the following onto the chalkboard (always try to do this before the lesson starts):

#### MY ROVER DESIGN

#### DESIGN BRIEF

I will design and make a \_\_\_\_\_ that will be able to travel \_\_\_\_\_ on a flat surface, carrying \_\_\_\_\_.

#### SPECIFICATIONS

1. The rover must be able to travel 2 metres on a flat surface. This must be unaided.
2. The rover must carry two small stones.
3. We can use elastic bands or balloons to power the rover.

#### CONSTRAINTS

The rover must be built in class.



## TOPIC: Systems to explore the Moon and Mars

2. Explain this to the learners as follows:
  - a. A design brief is a sentence saying what it is you are going to design and make.
  - b. Learners must complete the sentence.
  - c. Specifications tell you what the rover must have and be able to do.
  - d. Constraints are things you have to do.
3. Learners need to consider the following:
  - a. Is the rover going to be used on the Moon or Mars?
  - b. What shape will the frame of the rover be?
  - c. How will the rover be powered – elastic bands or a balloon?
  - d. Think about the materials that are needed to build the rover.
4. Give learners some time to copy the information from the chalkboard into their workbooks.

### **Checkpoint 1**

Ask the learners the following questions to check their understanding at this point:

- a. What two materials can you use to power your rover?
- b. What must your rover be able to carry as a load?

Answers to the checkpoint questions are as follows:

- a. Elastic bands, balloons
- b. Two stones

## **E**

### **CONCEPTUAL DEVELOPMENT**

1. Go over the following concepts with the learners before they start sketching their rovers:
  - a. Axles can be fixed or free-turning.
  - b. If axles are fixed, then the wheels will be free-turning.
  - c. If axles are free-turning, then the wheels will be fixed.
  - d. An axle should go through the centre of a wheel. Show learners Resource 32: 'How to make wheels and axles'.
  - e. Draw three diameters to find the centre of a wheel. Show learners Resource 34: 'Finding the centre of a wheel'.
  - f. Stoppers will stop the wheels from falling off the axle.
  - g. Spacers will stop the wheel from rubbing against the frame of the rover. Show learners Resource 35: 'Stoppers and Spacers'.
  - h. Model rovers can be powered by elastic bands or balloons. Show learners Resource 39: 'Elastic Bands and Axles'.
2. Write the following onto the chalkboard (always try to do this before the lesson starts):

## TOPIC: Systems to explore the Moon and Mars

### INSTRUCTIONS

1. Draw a sketch that includes:
  - a. a frame of the rover
  - b. somewhere for the two stones to be carried
  - c. how you are going to power your vehicle (elastic bands or balloons)
  - d. wheels and axles and how these will be attached to the frame of the rover with stoppers and spacers
  - e. labels the materials you will be using for the different parts
  - f. labels the different parts of the rover
  - g. a title with the name of your rover and whether it is a moon or Mars rover.
2. Make a list of all the materials that you will need to make the rover.
3. Explain this task to the learners as follows:
  - a. Each learner must make a sketch of their idea for a rover.
  - b. This sketch must include:
    - a place for the two stones to go
    - how the rover is going to be powered (elastic bands or balloons)
    - wheels and axles (show the learners Resource 33: 'How to fix axles onto the frame of the rover')
    - labels to explain the different parts of the rover
    - a title stating the name of the rover and whether it is a moon or Mars rover.
  - c. Each learner must make a list of materials that they will need in order to make the rover.
4. Give learners some time to complete the sketch and the list of materials in their workbooks.
5. When learners are finished with their sketches and the list of materials, they need to get into pairs. Each pair will decide on one rover to make between them.

### **Checkpoint 2**

Ask the learners the following questions to check their understanding at this point:

- a. What will the rover have to be able to do once it is made?
- b. What is the constraint for this design?

Answers to the checkpoint questions are as follows:

- a. Travel two metres on a flat surface with two stones
- b. The model must be built in class

6. Ask the learners if they have any questions and provide answers and explanations.

## TOPIC: Systems to explore the Moon and Mars

### F REFERENCE POINTS FOR FURTHER DEVELOPMENT

If you need additional information or activities on this topic, you can find these in your textbook on the following pages:

NAME OF TEXTBOOK	TOPIC	PAGE NUMBER
Study & Master	Systems to explore the Moon and Mars	169-170
Viva	Systems to explore the Moon and Mars	206
Platinum	Systems to explore the Moon and Mars	215
Solutions for All	Systems to explore the Moon and Mars	318-322
Day-by-Day	Systems to explore the Moon and Mars	192-193
Oxford	Systems to explore the Moon and Mars	-
Spot On	Systems to explore the Moon and Mars	96-97
Top Class	Systems to explore the Moon and Mars	145-146
Sasol Inzalo BkB	Systems to explore the Moon and Mars	169-171

### G ADDITIONAL ACTIVITIES / READING

In addition, further reading, listening or viewing activities related to this sub-topic are available through the following web links:

n/a

## TOPIC: Systems to explore the Moon and Mars

# 7 C

### Term 4, Week 7, Lesson C

### Lesson Title: Vehicles used on the Moon and Mars

### Time for lesson: 1½ hours

## A

### POLICY AND OUTCOMES

<b>Sub-Topic</b>	Make a rover
<b>CAPS Page Number</b>	64

#### Lesson Objectives

By the end of the lesson, learners will be able to:

- choose appropriate materials
- make a chassis
- make a system of wheels and axles
- attach a power source to a vehicle

Specific Aims	1. DOING SCIENCE & TECHNOLOGY	✓
	2. KNOWING THE SUBJECT CONTENT & MAKING CONNECTIONS	
	3. UNDERSTANDING THE USES OF SCIENCES & INDIGENOUS KNOWLEDGE	

### SCIENCE PROCESS SKILLS

1. Accessing & recalling Information	✓	7. Raising Questions		13. Interpreting Information	✓
2. Observing		8. Predicting		14. Designing	✓
3. Comparing		9. Hypothesizing		15. Making/ constructing	✓
4. Measuring		10. Planning Investigations	✓	16. Evaluating and improving products	
5. Sorting & Classifying		11. Doing Investigations	✓	17. Communicating	
6. Identifying problems & issues		12. Recording Information	✓		

## TOPIC: Systems to explore the Moon and Mars

### B POSSIBLE RESOURCES

For this lesson, you will need:

IDEAL RESOURCES	IMPROVISED RESOURCES
For wheels: bottle tops, cardboard, lids, or any other suitable materials	
For axles: kebab sticks, plastic straws, wooden dowel sticks, pencils, plastic or steel rods, cellotape, or any other suitable materials	
For the <b>chassis</b> : wooden dowels, cardboard, wire, glue, elastic bands, balloons	
Tools required: long-nose pliers to cut and bend wire, scissors, a small hammer, glue gun (not necessary), nails to make holes	
Resource 39: Elastic Bands and axles	

### C CLASSROOM MANAGEMENT

1. Make sure that you are ready and prepared.
2. Write the following question onto the chalkboard before the lesson starts:

How far will your rover have to travel?

3. Learners should enter the classroom and answer the question in their workbooks.
4. Discuss the answer with the learners.
5. Write the model answer onto the chalkboard.

*2 metres*

### D ACCESSING INFORMATION

1. Write the following onto the chalkboard (always try to do this before the lesson starts):

#### MAKING YOUR ROVER

Before you start making your rover, make sure you:

- have the sketch for the rover
- have a list of materials
- gather materials according to this list

After you make your rover, make sure you:

- test and improve your rover
- tidy up your workspace.

## TOPIC: Systems to explore the Moon and Mars

2. Read through the list above to make sure that learners understand the planning before they start making their rovers.

### **Checkpoint 1**

Ask the learners the following questions to check their understanding at this point:

- a. What is a fixed axle?
- b. Why must axles be parallel to each other?

Answers to the checkpoint questions are as follows:

- a. An axle that does not turn
- b. So that the vehicle can travel efficiently in a straight line

## **E**

### **CONCEPTUAL DEVELOPMENT**

1. Write the following onto the chalkboard (always try to do this before the lesson starts):

#### MAKING YOUR ROVER

Checklist:

- a. Have you collected all the materials that you will need to make your rover before you start?
- b. Have you got your design sketch in front of you?
- c. Have you remembered to put spacers and stoppers on the axles?
- d. Are the axles parallel to each other?
- e. Did you observe the safety rules? No running, no shouting, hold scissors downwards when walking.
- f. Did you test the rover to see if it need improvements.?
- g. Have you put your rover in a safe place for next week?
- h. Have you tidied up your work space?

Some tips:

- a. If your axle is fixed, then make a hole in the chassis that is a bit smaller than the diameter of the axle.
- b. If your axle is free-turning, then make a hole in the chassis a bit bigger than the diameter of the axle.

2. Explain this to the learners as follows:
  - a. You will make a rover together with your partner.
  - b. When making a model, learners must observe safety rules: no running, no shouting, hold scissors downwards when walking.
  - c. Go through the checklist and tips on the chalkboard.
  - d. Tell learners to not waste materials.

## TOPIC: Systems to explore the Moon and Mars

3. Allow learners time to make and test their rovers.
4. Tell learners to leave their rovers in a safe place for the next lesson.

### **F** REFERENCE POINTS FOR FURTHER DEVELOPMENT

If you need additional information or activities on this topic, you can find these in your textbook on the following pages:

NAME OF TEXTBOOK	TOPIC	PAGE NUMBER
Study & Master	Systems to explore the Moon and Mars	170-172
Viva	Systems to explore the Moon and Mars	206
Platinum	Systems to explore the Moon and Mars	215
Solutions for All	Systems to explore the Moon and Mars	322-326
Day-by-Day	Systems to explore the Moon and Mars	193
Oxford	Systems to explore the Moon and Mars	-
Spot On	Systems to explore the Moon and Mars	90
Top Class	Systems to explore the Moon and Mars	146
Sasol Inzalo BkB	Systems to explore the Moon and Mars	173-176

### **G** ADDITIONAL ACTIVITIES / READING

In addition, further reading, listening or viewing activities related to this sub-topic are available through the following web links:

n/a

## TOPIC: Systems to explore the Moon and Mars

# 8 A

### Term 4, Week 8, Lesson A

### Lesson Title: Vehicles used on the Moon and Mars

### Time for lesson: 1 hour

## A POLICY AND OUTCOMES

<b>Sub-Topic</b>	Evaluate the rover
<b>CAPS Page Number</b>	64

### Lesson Objectives

By the end of the lesson, learners will be able to:

- evaluate a rover
- work out how to improve the design

Specific Aims	1. DOING SCIENCE & TECHNOLOGY	✓
	2. KNOWING THE SUBJECT CONTENT & MAKING CONNECTIONS	✓
	3. UNDERSTANDING THE USES OF SCIENCES & INDIGENOUS KNOWLEDGE	

### SCIENCE PROCESS SKILLS

1. Accessing & recalling Information	✓	7. Raising Questions		13. Interpreting Information	✓
2. Observing		8. Predicting		14. Designing	
3. Comparing		9. Hypothesizing		15. Making/ constructing	
4. Measuring		10. Planning Investigations		16. Evaluating and improving products	✓
5. Sorting & Classifying		11. Doing Investigations		17. Communicating	
6. Identifying problems & issues		12. Recording Information	✓		



## TOPIC: Systems to explore the Moon and Mars

### B POSSIBLE RESOURCES

For this lesson, you will need:

#### Ideal Resources

-

#### Improvised Resources

-

### C CLASSROOM MANAGEMENT

1. Make sure that you are ready and prepared.
2. Write the following question onto the chalkboard before the lesson starts:

What are design specifications?

3. Learners should enter the classroom and answer the question in their workbooks.
4. Discuss the answer with the learners.
5. Write the model answer onto the chalkboard.

*Things that your design has to have or do.*

### D ACCESSING INFORMATION

1. Write the following onto the chalkboard (always try to do this before the lesson starts):

#### EVALUATE YOUR ROVER

- a. Can the rover carry two small stones?
  - b. Can the rover travel two metres?
  - c. Do the wheels roll easily or could there be some improvements?
  - d. Does the rover travel in a straight line or does it curve?
  - e. Is the body of the rover strong enough?
2. Explain this to the learners as follows:
    - a. The evaluation of your rover is based on the specifications.
    - b. It is important to evaluate the rover so that it can be improved upon.
  3. Give learners some time to copy the information from the chalkboard into their workbooks.

#### Checkpoint 1

Ask the learners the following questions to check their understanding at this point:

- a. Why is it important to evaluate a product?
- b. Why is it important for the rover to travel in a straight line?

Answers to the checkpoint questions are as follows:

- a. So that it can be improved.
- b. If it travelled in a curve it would go around in a circle, and it needs to explore Mars / the Moon.

## TOPIC: Systems to explore the Moon and Mars

### E CONCEPTUAL DEVELOPMENT

1. Let each group of learners demonstrate their rover to the rest of the class.
2. Evaluate each rover by going through the list of questions on the chalkboard.
3. Tell learners to open their workbooks. Learners must write one or two sentences explaining how they could improve their rovers.
4. Ask the learners if they have any questions and provide answers and explanations.

### F REFERENCE POINTS FOR FURTHER DEVELOPMENT

If you need additional information or activities on this topic, you can find these in your textbook on the following pages:

NAME OF TEXTBOOK	TOPIC	PAGE NUMBER
Study & Master	Systems to explore the Moon and Mars	172-173
Viva	Systems to explore the Moon and Mars	207
Platinum	Systems to explore the Moon and Mars	216
Solutions for All	Systems to explore the Moon and Mars	327
Day-by-Day	Systems to explore the Moon and Mars	193
Oxford	Systems to explore the Moon and Mars	-
Spot On	Systems to explore the Moon and Mars	99
Top Class	Systems to explore the Moon and Mars	146
Sasol Inzalo BkB	Systems to explore the Moon and Mars	176

### G ADDITIONAL ACTIVITIES / READING

In addition, further reading, listening or viewing activities related to this sub-topic are available through the following web links:

n/a

## TOPIC: Systems to explore the Moon and Mars

# 8 B

### Term 4, Week 8, Lesson B

### Lesson Title: Vehicles used on the Moon and Mars

### Time for lesson: 1½ hours

#### A POLICY AND OUTCOMES

<b>Sub-Topic</b>	Test the Rover
<b>CAPS Page Number</b>	64

#### Lesson Objectives

By the end of the lesson, learners will be able to:

- measure the distances travelled by the model rovers
- record observations

Specific Aims	1. DOING SCIENCE & TECHNOLOGY	✓
	2. KNOWING THE SUBJECT CONTENT & MAKING CONNECTIONS	
	3. UNDERSTANDING THE USES OF SCIENCES & INDIGENOUS KNOWLEDGE	

#### SCIENCE PROCESS SKILLS

1. Accessing & recalling Information	✓	7. Raising Questions		13. Interpreting Information	✓
2. Observing	✓	8. Predicting		14. Designing	✓
3. Comparing		9. Hypothesizing		15. Making/ constructing	
4. Measuring		10. Planning Investigations		16. Evaluating and improving products	
5. Sorting & Classifying		11. Doing Investigations	✓	17. Communicating	✓
6. Identifying problems & issues		12. Recording Information	✓		

## TOPIC: Systems to explore the Moon and Mars

### B POSSIBLE RESOURCES

For this lesson, you will need:

IDEAL RESOURCES	IMPROVISED RESOURCES
two bricks	a piece of string that measures a metre, with marks representing $\frac{1}{2}$ m, $\frac{1}{4}$ m.
wooden plank or sheet of cardboard	
measuring tape or metre stick	
the rovers	

### C CLASSROOM MANAGEMENT

1. Make sure that you are ready and prepared.
2. Write the following question onto the chalkboard before the lesson starts:

Why do we evaluate our rovers?

3. Learners should enter the classroom and answer the question in their workbooks.
4. Discuss the answer with the learners.
5. Write the model answer onto the chalkboard.

*So that we can improve them.*

### D ACCESSING INFORMATION

1. Write the following onto the chalkboard (always try to do this before the lesson starts):

NAMES OF ROVERS	DISTANCE ROVER TRAVELLED (CENTIMETRES)					
	One brick ramp			Two brick ramp		
	Run 1	Run 2	Run 3	Run 1	Run 2	Run 3
(Name of my group's rover)						
(Name of one other group's rover)						

2. Explain this to the learners as follows:
  - a. Each rover will first travel down a one brick high ramp.
  - b. The distance the rover travelled from the bottom of the ramp to where it stopped will be measured. The measurement will be from the bottom of the ramp to the rover's front wheels.
  - c. Each learner will record the data from two rovers only – their rover and one other group.
  - d. Learners will record these distances on the table.
  - e. Each rover will have three attempts at each height.

## TOPIC: Systems to explore the Moon and Mars

- f. When all rovers have completed the one brick ramp, the rovers will then be sent down the two-brick ramp.
  - g. The distance will be recorded in centimeters.
3. Give learners some time to copy this information into their workbooks.

### **Checkpoint 1**

Ask the learners the following questions to check their understanding at this point:

- a. What sort of energy does the rover have when it is being held at the top of the ramp?
- b. What sort of energy does this convert to once the rover is let go?

Answers to the checkpoint questions are as follows:

- a. Potential energy
- b. Kinetic energy

## **E**

### **CONCEPTUAL DEVELOPMENT**

1. Set up the ramp by putting one brick under the wooden plank at one end. Make sure there is a big enough flat surface for the rovers to travel on after it gets off the ramp.
2. Learners will record their own distances and the distances of one other group.
3. All rovers must be placed with their back wheels lined up with the back of the plank.
4. Rovers must not be pushed; learners must let them go by releasing them.
5. Results must be recorded on the table in centimetres.
6. After each rover has been down the one brick ramp three times, raise the plank with another brick.
7. Ask the learners what they think will happen? The rovers will travel faster and further.
8. Ask learners why they think this will happen? The potential energy is larger when the slope is steeper.
9. All rovers must be sent down the plank and the distance measured.
10. These results must be recorded on the table.
11. Give learners some time to complete this task in their workbooks.

### **Checkpoint 1**

Ask the learners the following questions to check their understanding at this point:

- a. When does the ramp have more potential energy: one brick high or two bricks high?
- b. Why must we be careful to measure all the distances in the same way?

Answers to the checkpoint questions are as follows:

- a. Two bricks high
- b. So that the data is fair and accurate

12. Ask the learners if they have any questions and provide answers and explanations.

## TOPIC: Systems to explore the Moon and Mars

### F REFERENCE POINTS FOR FURTHER DEVELOPMENT

If you need additional information or activities on this topic, you can find these in your textbook on the following pages:

NAME OF TEXTBOOK	TOPIC	PAGE NUMBER
Study & Master	Systems to explore the Moon and Mars	170-172
Viva	Systems to explore the Moon and Mars	206
Platinum	Systems to explore the Moon and Mars	215
Solutions for All	Systems to explore the Moon and Mars	322-326
Day-by-Day	Systems to explore the Moon and Mars	193
Oxford	Systems to explore the Moon and Mars	-
Spot On	Systems to explore the Moon and Mars	90
Top Class	Systems to explore the Moon and Mars	146
Sasol Inzalo Bk B	Systems to explore the Moon and Mars	173-176

### G ADDITIONAL ACTIVITIES / READING

In addition, further reading, listening or viewing activities related to this sub-topic are available through the following web links:

n/a

## TOPIC: Systems to explore the Moon and Mars

# 8 C

### Term 4, Week 8, Lesson C

### Lesson Title: Vehicles used on the Moon and Mars

### Time for lesson: 1 hour

## A

### POLICY AND OUTCOMES

<b>Sub-Topic</b>	Draw graphs
<b>CAPS Page Number</b>	64

#### Lesson Objectives

By the end of the lesson, learners will be able to:

- analyse data
- draw a bar graph

Specific Aims	1. DOING SCIENCE & TECHNOLOGY	✓
	2. KNOWING THE SUBJECT CONTENT & MAKING CONNECTIONS	
	3. UNDERSTANDING THE USES OF SCIENCES & INDIGENOUS KNOWLEDGE	

### SCIENCE PROCESS SKILLS

1. Accessing & recalling Information	✓	7. Raising Questions		13. Interpreting Information	✓
2. Observing	✓	8. Predicting		14. Designing	
3. Comparing	✓	9. Hypothesizing		15. Making/ constructing	
4. Measuring		10. Planning Investigations		16. Evaluating and improving products	
5. Sorting & Classifying		11. Doing Investigations	✓	17. Communicating	✓
6. Identifying problems & issues		12. Recording Information	✓		

## TOPIC: Systems to explore the Moon and Mars

### B POSSIBLE RESOURCES

For this lesson, you will need:

IDEAL RESOURCES	IMPROVISED RESOURCES

### C CLASSROOM MANAGEMENT

1. Make sure that you are ready and prepared.
2. Write the following question onto the chalkboard before the lesson starts:

What happened to the rovers when a ramp was made higher?

3. Learners should enter the classroom and answer the question in their workbooks.
4. Discuss the answer with the learners.
5. Write the model answer onto the chalkboard.

*They travelled faster and further.*

### D ACCESSING INFORMATION

1. Write the following onto the chalkboard (always try to do this before the lesson starts):

#### PUTTING INFORMATION IN A GRAPH

- a. A bar graph is one type of graph.
  - b. It has bars of different heights to show the different measurements.
  - c. The measurements go along the left-side of the graph (vertical axis).
  - d. The objects being measured go along the bottom line (horizontal axis).
  - e. The distance travelled (in centimetres) will be placed along the vertical axis.
  - f. The rovers' names will be placed along the horizontal axis.
2. Explain this to the learners as follows:
    - a. Bar graphs let us see quickly what the distances travelled were.
    - b. Draw a separate bar graph for the one brick ramp and the two-brick ramp. Each learner will record the data from two rovers only – their rover and one other group.
  3. Give learners some time to copy the information from the chalkboard into their exercise books.



# TOPIC: Systems to explore the Moon and Mars

## Checkpoint 1

Ask the learners the following questions to check their understanding at this point:

- a. What do stoppers do?
- b. What do spacers do?

Answers to the checkpoint questions are as follows:

- a. Stoppers stop the wheel from falling off the axle.
- b. Spacers stop the wheel from touching the body of the rover, and therefore slowing them down.

## E CONCEPTUAL DEVELOPMENT

1. Draw the following onto the chalkboard:

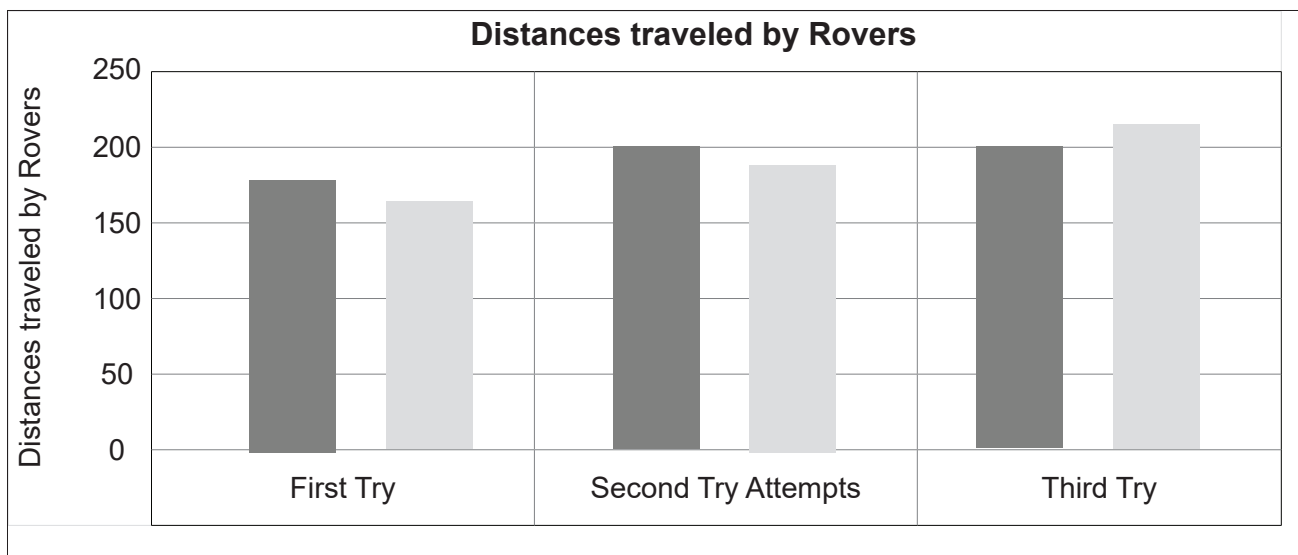
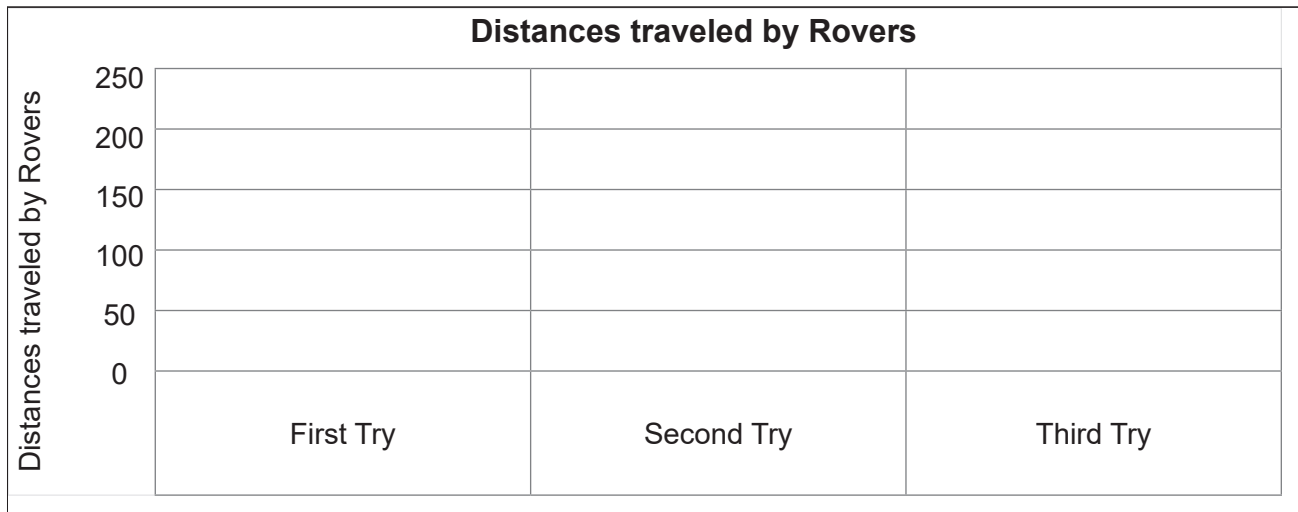

## TOPIC: Systems to explore the Moon and Mars

2. Explain this task to the learners as follows:
  - a. You will draw the bar graph with the correct labels and title as shown at the top of the chalkboard.
  - b. Along the left-side (vertical axis) with the label 'Distance travelled by Rovers', place the following numbers starting at the bottom line: 0; 50; 100; 150; 200; 250.
  - c. Along the bottom of the graph, choose a colour or pattern for each rover.
  - d. Give your bar graph a title 'Distance travelled by Rovers'.
  - e. Fill in your bars by getting the data from the table in the previous lesson. Try to be as accurate as possible.
  - f. Start with the first try by each rover.
  - g. Then leave a gap and do the second try.
  - h. Leave a gap and do the third try.
  - i. Draw a border around the bar graph.
  - j. Do a second bar graph for the distances when the ramp was lifted with two bricks.
3. Give learners some time to complete this task in their workbooks.

### **Checkpoint 2**

Ask the learners the following questions to check their understanding at this point:

- a. A bar graph has lines to show the data. True or False.
- b. What goes along the left-side axis of a bar graph?

Answers to the checkpoint questions are as follows:

- a. False. It has bars to show the data.
- b. Measurements.

4. Ask the learners if they have any questions and provide answers and explanations.

## TOPIC: Systems to explore the Moon and Mars

### F REFERENCE POINTS FOR FURTHER DEVELOPMENT

If you need additional information or activities on this topic, you can find these in your textbook on the following pages:

NAME OF TEXTBOOK	TOPIC	PAGE NUMBER
Study & Master	Systems to explore the Moon and Mars	-
Viva	Systems to explore the Moon and Mars	-
Platinum	Systems to explore the Moon and Mars	216
Solutions for All	Systems to explore the Moon and Mars	327
Day-by-Day	Systems to explore the Moon and Mars	194
Oxford	Systems to explore the Moon and Mars	-
Spot On	Systems to explore the Moon and Mars	99
Top Class	Systems to explore the Moon and Mars	-
Sasol Inzalo BkB	Systems to explore the Moon and Mars	-

### G ADDITIONAL ACTIVITIES / READING

In addition, further reading, listening or viewing activities related to this sub-topic are available through the following web links:

1. <https://www.mathsisfun.com/data/bar-graph.html> [Make a bar graph]

NATURAL  
SCIENCES  
&  
TECHNOLOGY  
ASSESSMENT  
GRADE 6 TERM 4



## GRADE 6 ASSESSMENT

- This section presents the CAPS assessment requirements for this grade for this term.
- See your prescribed textbooks for examples of the required assessments.

### CAPS Assessment

Assessment is a continuous planned process that involves identifying, gathering, interpreting and diagnosing information about the performance of learners.

Assessment involves generating and collecting evidence of learner achievement and progress, and using this information to understand and provide assistance to the learner during the process of teaching and learning.

Assessment should be both *formal* and *informal*:

- a. Informal Assessment** involves regular checking of learners' class work and practical tasks; asking questions; discussions; informal classroom interactions; and giving constructive feedback. Informal assessment marks do not need to be recorded, but the teacher can make notes for future reference.
- b. Formal Assessment** provides teachers with a systematic way of evaluating how well learners are progressing. Formal Assessment consists of selected assessment tasks. These tasks are stipulated by CAPS and the marks need to be recorded. These tasks are done throughout the year, and include practical tasks, tests and examinations.

- i. Tests and Examinations**

Examinations must include questions on both Natural Sciences and Technology. The weighting of the marks should reflect the time allocated to each section in the curriculum content. Tests and exams should consist of a range of questions that cover different cognitive levels: recall; understanding; application; evaluation; analysis; and synthesis. CAPS aligned tests and examinations, with accompanying memoranda, are provided with these lesson plans.

- ii. Practical Tasks**

Practical tasks give learners the opportunity to demonstrate knowledge, skills and understanding. Practical tasks form part of the activities included in these lesson plans. Each term, one practical task has been selected for assessment. A rubric is provided to conduct the assessment.

A minimum mark allocation is prescribed in CAPS for tests, practical tasks and examinations for each grade. For this grade, these are summarised in the table below:

# GRADE 6 ASSESSMENT

## Grade 6

### Programme of Formal Assessment

Formal Assessments	TERM 1	TERM 2	TERM 3	TERM 4	TOTAL MARKS FOR THE YEAR	TOTAL
<b>School-based assessments</b>	1 test [20 marks]  1 selected practical task [15 marks]	1 exam or test on work from terms 1 & 2 [50 marks]  1 selected practical task [15 marks]	1 test [20 marks]  1 selected practical task [15 marks]	1 selected practical task [15 marks]	150 marks	Together make up 75% of the total marks of the year
<b>Exams [60 minutes]</b>				Exam on work from terms 3 & 4 [50 marks]	50 marks	Makes up 25% of the total marks of the year
<b>Number of formal assessments</b>	2	2	2	2	Total 8 assessments [200 marks]	Total: 100%

Refer to CAPS on the processes for converting marks to percentages and to the 7-point scale.

In this section of the booklet, you will find your science assessments for this term.

There are two assessments included:

#### A Practical Activity

The activity completed is drawn from one of the lessons in the lesson plans. The rubric or memorandum attached in this pack will assist you with assessing the task completed by the learners.

#### An Exam

The exam included will need to be copied onto the chalkboard for learners to complete. There is also an exam memorandum included to assist you with marking the learners completed test scripts.

All of the assessments are aligned to CAPS requirements and the marks allocated for each assessment are as stipulated in CAPS.

## Natural Sciences & Technology

### Grade 6

### Practical Task

### Term 4

### 15 Marks

**Time allocation: 40 minutes (15 minutes preparation, 25 minutes task time)**

#### NOTE TO THE TEACHER:

1. This practical activity will be completed as part of Section E of lesson 3C.
2. This practical will take place during the lesson after the teaching component in Section D, "Accessing Information".
3. The first 15 minutes will be used to teach section D and prepare learners for the practical task.
4. The next 25 minutes will be used to complete the practical activity as outlined in Section E.
5. The instructions and content of the practical task should be written on the chalkboard, before the lesson for the learners.
6. The memo for assessing the practical task is provided.
7. The learners will be working as a class and will need the following to complete the tasks:
  - A balloon (have a spare balloon available)
  - A permanent marker or koki pen
  - ½m string or wool
  - A torch (you can use your cellphone torch or a mirror to reflect sunlight)
  - A map of Africa
8. Ensure that all the materials have been collected before the practical lesson. This may take a few days. Allow enough time for this.
9. The learners should complete the drawings with a sharp pencil and the written answers should be completed in pen.

# GRADE 6 ASSESSMENT – PRACTICAL TASK TERM 4

## MAP OF AFRICA





# GRADE 6 ASSESSMENT – PRACTICAL TASK TERM 4 MEMO

## Grade 6 Natural Sciences & Technology Term 4

### Practical Task Memorandum

(see Section E of Lesson 3C for instructions and questions)

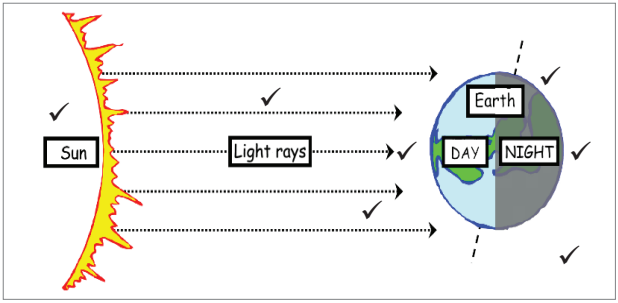
CAPS Topic	Task	Expected answer/outcome	Marks
Movements of the Earth and Planets	1	The balloon represents the Earth ✓	1
Movements of the Earth and Planets	2	The torch represents the Sun ✓	1
Movements of the Earth and Planets	3	The Earth spins on its axis ✓	2
Movements of the Earth and Planets	4	24 hours ✓	1
Movements of the Earth and Planets	5	Durban ✓	1
Movements of the Earth and Planets	6	The part that is away from the sun ✓	1
Movements of the Earth and Planets	7	 <p style="text-align: center;"><u>Diagram to show day and night</u> ✓</p>	8
<b>TOTAL 15</b>			

**Grade 6**  
**Natural Sciences & Technology**  
**Term 4**  
**Exam**

**50 Marks**  
**60 Minutes**

**NOTE TO THE TEACHER:**

If possible, photocopy this exam for each learner. If this is not possible, write the exam on the chalkboard.

**INSTRUCTIONS TO THE LEARNERS**

1. Answer all questions in blue or black ink.
2. Read each question carefully before answering it.
3. Pay attention to the mark allocations.
4. Plan your time carefully.
5. Write your answers in the spaces provided.
6. Write neatly.

**PRACTICE QUESTION**

Read the question and circle the letter that shows the correct answer.

- 1.1. Which planet in our solar system is closest to the sun?
- a. Neptune
  - b. Mercury
  - c. Earth
  - d. Saturn.

You have answered correctly if you have circled **B**

# GRADE 6 ASSESSMENT – EXAM TERM 4

## SECTION A: Energy and Change

### QUESTION 1: MULTIPLE CHOICE

[5]

Read each question and circle the letter that shows the correct answer.

1.1. In which of the following circuits will the bulb/s light up?

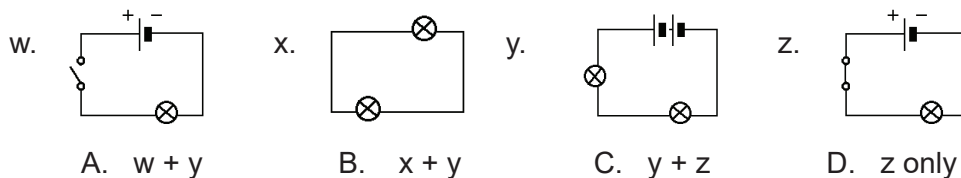

1.2. In a simple series circuit, why does the bulb light go on when you close the switch?

- a. Because the switch produces electricity.
- b. Because closing the switch completes the circuit.
- c. Because closing the switch breaks the circuit.
- d. Because the switch shorts electricity.

1.3. Imagine a simple series circuit with one 1,5V battery and 1 bulb. When you add a second 1,5V battery:

- a. The bulb gets brighter.
- b. The bulb gets dimmer.
- c. The bulb stays at the same level of brightness.
- d. The bulb does not shine.

1.4. In a circuit diagram, what does a circle with a cross inside it represent?

- a. Bulb.
- b. Battery.
- c. Wire.
- d. Switch.

1.5. Which component is grouped with its symbol:

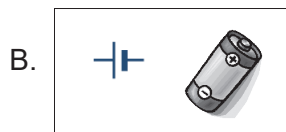
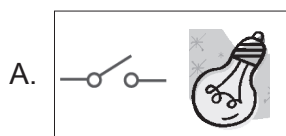

## GRADE 6 ASSESSMENT – EXAM TERM 4

### QUESTION 2

[5]

Write one word that means the same as the sentence:

2.1. Stored energy.

\_\_\_\_\_

2.2. A material that allows electricity to pass through it.

\_\_\_\_\_

2.3. A component used to turn electricity on and off.

\_\_\_\_\_

2.4. Movement energy.

\_\_\_\_\_

2.5. A material that does not allow electricity to pass through it.

\_\_\_\_\_

### QUESTION 3: MATCH THE COLUMNS

[5]

Instructions:

- Match the sentences in COLUMN A with the words in COLUMN B.
- Draw a line to join the sentence in COLUMN A with the correct word in COLUMN B. Do this as shown in the example.

COLUMN A	
example	Conducts electricity
3.1.	Is a renewable source of energy
3.2.	A source of electrical energy
3.3.	A fossil fuel
3.4.	An insulator
3.5.	A device that transfers energy for a useful purpose

COLUMN B
A. Batteries
B. Coal
C. Buzzer
D. Rubber
E. Metal
F. Wind

# GRADE 6 ASSESSMENT – EXAM TERM 4

## QUESTION 4

[6]

Answer the following questions:

4.1. Name the three components that make up a simple electric circuit. (3)

---

---

---

4.2. What is an electric circuit? (3)

---

---

---

## QUESTION 5

[4]

Write down the energy conversion for each of the following items. (Eg: electrical energy to heat energy).

5.1.



Electrical energy to

---

---

5.2.



Electrical energy to

---

---

5.3.

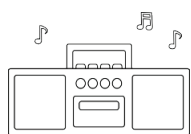

Electrical energy to

---

---

5.4.



Electrical energy to

---

---

## GRADE 6 ASSESSMENT – EXAM TERM 4

### QUESTION 6 : DRAWING CIRCUIT DIAGRAMS

[5]

6.1. Use the correct symbols to draw the circuit diagram for the drawing.

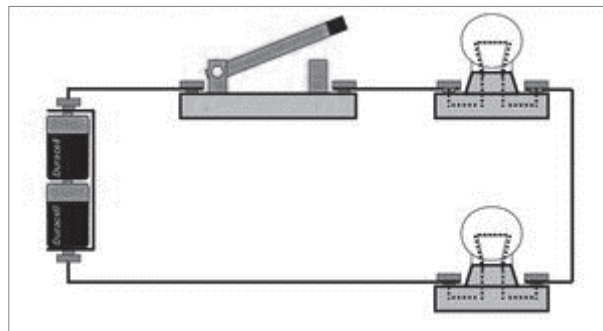

### SECTION B: Planet Earth and Beyond

#### QUESTION 1: MULTIPLE CHOICE

[6]

Read each question and circle the letter that shows the correct answer.

1.1. Choose the answer that is false. The sun is...

- a. a ball of gases
- b. a star
- c. 420 times bigger than earth
- d. smaller than earth

1.2. Which planet is furthest from the sun?

- a. Mars
- b. Neptune
- c. Venus
- d. Mercury

1.3. The four rocky planets are:

- a. Earth, Venus, Mercury and Mars
- b. Venus, Jupiter, Mars and Neptune
- c. Earth, Saturn, Venus and Mars
- d. Uranus, Earth, Mars and Mercury

## GRADE 6 ASSESSMENT – EXAM TERM 4

1.4. The asteroid belt is between:

- a. Mars and Venus
- b. Neptune and Uranus
- c. Mars and Jupiter
- d. Mercury and Venus

1.5. Which planet is known as the red planet?

- a. Mars
- b. Neptune
- c. Venus
- d. Mercury

### QUESTION 2

[5]

Write one word that means the same as the sentence:

2.1. Rocks that travel through space at very fast speeds.

\_\_\_\_\_

2.2. The force that pulls everything towards the Earth.

\_\_\_\_\_

2.3. A hole on the surface of the moon.

\_\_\_\_\_

2.4. An imaginary line running through a planet, from top to bottom.

\_\_\_\_\_

2.5. The name given to the 4 outer planets.

\_\_\_\_\_

## GRADE 6 ASSESSMENT – EXAM TERM 4

### QUESTION 3

[9]

Answer in full sentences.

3.1. What is at the centre of the solar system? (1)

\_\_\_\_\_

3.2. Explain the difference between rotation and revolution. (4)

\_\_\_\_\_

\_\_\_\_\_

\_\_\_\_\_

\_\_\_\_\_

3.3. Give 2 reasons as to why you can still see a footprint on the moon? (4)

\_\_\_\_\_

\_\_\_\_\_

\_\_\_\_\_

\_\_\_\_\_

### QUESTION 4

[5]

Write the name of the planet next to the description.

4.1. The smallest planet - \_\_\_\_\_

4.2. Has 7 rings around it - \_\_\_\_\_

4.3. Is the coldest planet - \_\_\_\_\_

4.4. Can support life - \_\_\_\_\_

4.5. The largest planet - \_\_\_\_\_



# GRADE 6 ASSESSMENT – EXAM TERM 4

Question 5

[6]

5.1.

Fill in the labels of the diagram and write a heading below.

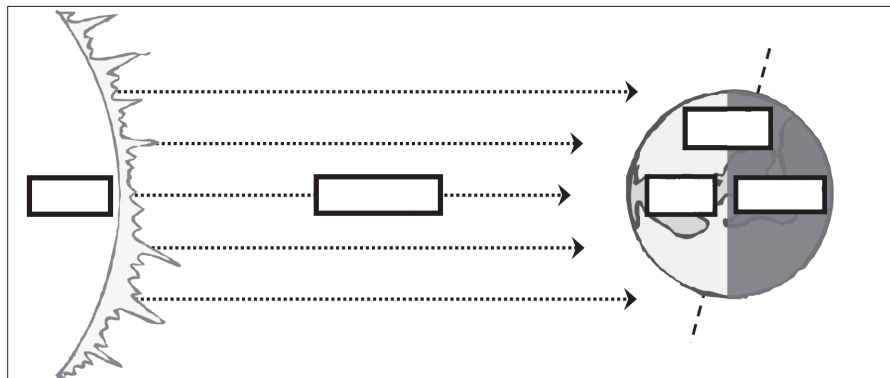

Heading: \_\_\_\_\_ ✓

**TOTAL 60**

# GRADE 6 ASSESSMENT – EXAM TERM 4 MEMO

## Grade 6 Natural Sciences & Technology Term 4 Exam

### Memorandum

CAPS Topic	Questions	Expected answer(s)	Marks
<b>PART A: Energy and Change</b>			
	1		
Electric circuits	1.1	D ✓	1
Electric circuits	1.2	B ✓	1
Electric circuits	1.3	A ✓	1
Electric circuits	1.4	A ✓	1
Electric circuits	1.5	B ✓	1
	2		
Energy and electricity	2.1	Potential energy ✓	1
Conductors and insulators	2.2	Conductor ✓	1
Electric circuits	2.3	Switch ✓	1
Energy and electricity	2.4	Kinetic energy ✓	1
Conductors and insulators	2.5	Insulator ✓	1
	3		
Energy around us	3.1	F ✓	1
Energy around us	3.2	A ✓	1
Energy around us	3.3	B ✓	1
Conductors and insulators	3.4	D ✓	1
Electric circuits	3.5	C ✓	1
	4		
Electric circuits	4.1	<ul style="list-style-type: none"> <li>• A source of electrical energy – battery ✓</li> <li>• Conducting material – electric wire ✓</li> <li>• A device that transfers energy for a useful purpose – bulb/buzzer/motor ✓</li> </ul>	3
Electric circuits	4.2	A circuit is a complete ✓ path ✓ around which electricity can flow. ✓	3
	5		
Electric circuits	5.1	Light energy ✓	1
Electric circuits	5.2	Movement energy ✓	1
Electric circuits	5.3	Sound energy ✓	1
Electric circuits	5.4	Heat energy	1

## GRADE 6 ASSESSMENT – EXAM TERM 4 MEMO

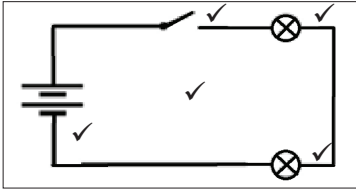
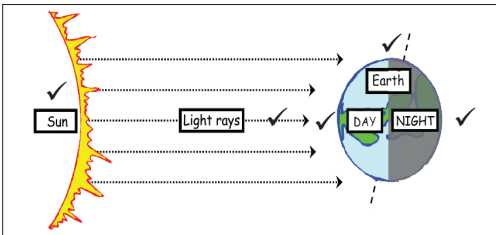
	6		
Electric circuits	6.1		5
<b>PART B: Earth and Beyond</b>			
	1		
The solar system	1.1	D ✓	1
The solar system	1.2	B ✓	1
The solar system	1.3	A ✓	1
The solar system	1.4	C ✓	1
The solar system	1.5	A ✓	1
	2		
The solar system	2.1	Asteroids ✓	1
The solar system	2.2	Gravity ✓	1
The solar system	2.3	Crater ✓	1
The solar system	2.4	Axis ✓	1
The solar system	2.5	Gaseous ✓	1
	3		
The solar system	3.1	The sun ✓	1
The solar system	3.2	<ul style="list-style-type: none"> <li>• Rotation – the Earth rotates on its axis which takes 24 hours. ✓ ✓</li> <li>• Revolution – the Earth revolves around the sun which takes 365¼ days. ✓ ✓</li> </ul>	4
The solar system	3.3	<ul style="list-style-type: none"> <li>• There is no wind to blow the footprint away. ✓ ✓</li> <li>• There is no water to wash the footprint away. ✓ ✓</li> </ul>	4
	4		
The solar system	4.1	Mercury ✓	1
The solar system	4.2	Saturn ✓	1
The solar system	4.3	Neptune ✓	1
The solar system	4.4	Earth ✓	1
The solar system	4.5	Jupiter ✓	1
	5		
The solar system	5.1	 <p style="text-align: center;"><u>Diagram to show day and night</u> ✓</p>	6
<b>TOTAL</b>			<b>60</b>